

THE UNIVERSITY OF CALGARY

Two Subject Positions and a Functional Category *Predicate*

by

Fumiko Watai

A THESIS

SUBMITTED TO THE FACULTY OF GRADUATE STUDIES
IN PARTIAL FULFILLMENT OF THE REQUIREMENTS FOR THE
DEGREE OF MASTER OF ARTS

DEPARTMENT OF LINGUISTICS

CALGARY, ALBERTA

JULY, 1996

©Fumiko Watai 1996

THE UNIVERSITY OF CALGARY
FACULTY OF GRADUATE STUDIES

The undersigned certify that they have read, and recommend to the Faculty of Graduate Studies for acceptance, a thesis entitled "Two Subject Positions and a Functional Category *Predicate*" submitted by Fumiko Watai in partial fulfillment of the requirements for the degree of Master of Arts.



Supervisor, Dr. Elizabeth Ritter, Department of Linguistics



Dr. Eithne Guilfoyle, Department of Linguistics

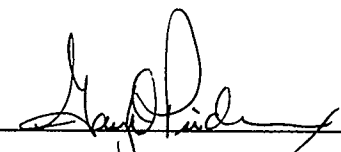

Dr. Gary Prideaux, Department of Linguistics
The University of Alberta

July 19, 1996
Date

ABSTRACT

This thesis explores the properties of a functional projection, Predicate Phrase(PrP) in the structure of clauses. PrP is located immediately above VP, and projects an event structure onto the syntax by introducing an event instigator which is denoted by the subject. Its semantic contribution consists of aspectual and thematic information pertaining to the subject argument.

This thesis also proposes a slight modification to the Agr-based Case theory of Chomsky (1992), proposing that Pr is an Accusative Case-bearing head. Based on this modification, we suggest that Nominative Case marking of the object in Japanese statives is due to the lack of PrP in noneventive structure.

Finally, causativization in Japanese is analyzed as the process of adding a second PrP containing a new event instigator. The second Pr is filled with an overt causative morpheme and a causer is inserted in Spec of this PrP.

ACKNOWLEDGEMENTS

It is time to put an end to this project. Not because it is completely done, but because one has to stop somewhere; otherwise questions keep arising and there seems to be no end to the endeavour.

My thesis adviser D. E. Ritter is the first I would like to thank for her extremely valuable input and guidance throughout the project. She has always been patient, caring and encouraging. Most of the insights of the thesis is the direct result of her suggestions, and her contributions are to be found throughout.

I am also grateful to the other faculty members. Linguistic classes I attended over the last three years were all stimulating and provided me the excitement of intellectual pursuits. Dr. Murray and Dr. Guilfoyle especially helped me both inside and outside of class throughout the duration of the program.

I would like to thank Dr. Prideaux for many valuable comments on the Japanese data.

During the course of my program, the Linguistics Department and the Dean's Office of the University of Calgary have offered financial aid in the form of a scholarship, and teaching and research assistantships. I would like to thank the Dean's Office and the Department for making my graduate study financially possible. I gratefully acknowledge financial support from SSHRCC grant #410-94-0478 to E. Ritter.

Thanks are also due to my fellow graduate students, Susan Armstrong, Julie Bailey, Naomi Sawai, Kerilee Snatenchuk, Robert South and Beata Widomska for their encouragement throughout the graduate program.

Finally there is my family: husband, Ken and children, Kenta, Yuko, Kengo and Nina. No offering of thanks will ever be adequate. Thank you for cooking, cleaning, washing

TABLE OF CONTENTS

APPROVAL PAGE	ii
ABSTRACT	iii
ACKNOWLEDGEMENTS	iv
TABLE OF CONTENTS	v
LIST OF ABBREVIATIONS	viii
Chapter 1 INTRODUCTION	1
1.1 Subjects	1
1.1.1 Subject position	1
1.1.2 Subject property mismatches	2
1.1.3 Problems and proposals	3
1.2 Framework	4
1.2.1 Split INFL hypothesis	4
1.2.2 Feature checking theory	6
1.3. Basic Sentence Structure and Case Marking in Japanese	7
1.3.1 Sentence structure and scrambling	8
1.3.2 Case Marking	8
1.4. Organization of the Thesis	8
Chapter 2 SUBJECT POSITION AND A FUNCTIONAL PROJECTION PrP	10
2.1 [Spec, IP] Subject Hypothesis and [Spec, VP] Subject Hypothesis	10
2.2 Arguments for the [Spec, VP] Subject Hypothesis	12
2.2.1 Quantifier floating (Sportiche 1988)	13
2.2.2 VP Coordination (McNally 1992, Burton and Grimshaw 1992)	13
2.3 Counterevidence to the [Spec, VP] Subject Hypothesis	16
2.3.1 Problems of Adjacency Condition (Johnson 1991)	16
2.3.2 Time phrases: Nakayama and Koizumi (1991)	19
2.3.3 VP-adjoined phrases and scrambling in Japanese	23

2.4 [Spec, PrP] Subject Hypothesis	30
2.5 Evidence for the [Spec, VP] Subject Hypothesis Revisited	31
2.5.1 Quantifier floating	32
2.5.2 VP Coordination	33
2.6 The Role of Pr in Event Structure	35
2.6.1 Event Structure (Van Voorst 1988)	36
2.6.2 Initiator subjects in Irish (Guilfoyle 1995)	38
2.6.3 Initiator subjects in Japanese	40
2.6.4 Properties of Pr in event structure	43
2.6.5 Unaccusative verbs	44
2.7 Summary	46
Chapter 3 VP-PREPOSING	47
3.1 The Internal Subject Hypothesis and VP-Preposing	48
3.2 Preposed Constituents	49
3.2.1 V'-preposing	49
3.2.2 VP-preposing with a subject trace	50
3.3 VP-Preposing in Japanese	52
3.3.1 Three Exceptions to VP-preposing	54
3.4 VP-External Subject Analysis & VP-preposing	57
3.5 Summary	63
Chapter 4 STATIVE VERBS	65
4.1 Introduction	65
4.2 Stative Verbs and the Subject in Japanese	65
4.3 VP-Preposing and Stative Verbs	69
4.4 Accusative Case and Pr	72
4.4.1 Case marking of the object and stativity	73
4.4.2 Case marking of the subject and stativity	75

4.4.3	Postposition <i>ni</i>	77
4.4.4	Pr as Accusative Case-bearing head	80
4.4.5	Scope of Negation	83
4.4.6	Further issues	85
4.5	Summary	86
Chapter 5 CAUSATIVES		87
5.1	Brief Summary of Japanese Causatives	88
5.1.1	A monoclausal or biclausal derivation ?	88
5.1.2	Lexical vs analytical causatives	92
5.2	Morphological Analysis of Causatives	93
5.2.1	Blocked causatives	94
5.2.2	Unblocked causatives	96
5.2.3	Summary of blocked and unblocked causatives	99
5.3	Structure of Japanese Causatives	100
5.3.1	Pr and causative	100
5.3.2	The structure of unblocked causatives	107
5.3.3	The structure of blocked causatives	109
5.3.4	The complement of the upper Pr	114
5.3.4.1	The Case properties of causative structure	115
5.3.4.2	Neg and Tense projections	121
5.4	Reflexive Binding	125
5.5	Summary	128
Chapter 6 CONCLUDING REMARKS		129
6.1	Concluding remarks	129
6.2	Further Issues	130
BIBLIOGRAPHY		135

LIST OF ABBREVIATIONS

ACC	Accusative Case
CL	classifier
COP	copula
Hon	honorification
N	nominalizer
NOM	Nominative Case
Pres	present tense
Prog	progressive
TOP	Topic marker

CHAPTER 1

INTRODUCTION

1.1 Subject

1.1.1 Subject position

Many contemporary linguists assume some kind of asymmetry between the subject of a sentence and the other arguments. Theories of argument structure generally agree that the thematic role assigned to the subject must somehow be set apart from the other thematic roles. Under a proposal by Williams (1980), the argument which must be realized in the subject position is singled out in the lexicon, and projected onto an NP outside VP. In Chomsky (1986), a transitive sentence such as *John cut the orange* is assumed to have the following D-structure:

(1) [_{IP} John INFL [_{VP} cut the orange]]

Since then, the [Spec, VP] Subject Hypothesis has been gaining ground in the literature (Kitagawa 1986, Fukui and Speas 1986, Kuroda 1988, Koopman and Sportiche 1991). According to this hypothesis, subjects of transitive and intransitive verbs are base-generated in Spec of VP, and raised to Spec of IP for Case reasons. The transitive sentence *John cut the orange* is assumed to have the following D-structure:

(2) [_{IP} INFL [_{VP} John [_{V'} cut the orange]]]

Subject Hypothesis have been observed. To avoid these problems, some linguists have proposed that the subject is generated in Spec of a phrase above VP, but below IP. Among them are Johnson (1991), Bowers (1993), Kratzer (1993), Koizumi (1993), Pesetsky (1994), Travis (1994), Guilfoyle (1995) and Harley (1995).

1.1.2 Subject property mismatches

In addition to the disagreement over the base position of the subject, there is another more fundamental question: whether there is any single subject position which satisfies all the well-formedness constraints and allows the subject to exhibit all relevant properties. Harley (1995) writes "It has long been recognized that the set of subject properties that characterize a canonical subject in a highly 'subject-prominent' language cannot be linked to a single position." (pp.13-14) One of her examples comes from the Japanese stative verb structure. In Japanese, subjects are normally marked with the Nominative Case marker *-ga*, and objects are marked with the Accusative Case marker *-o*. When a verb is stative, however, the subject appears with the postposition *-ni*, and the object bears a Nominative Case marker as shown in (3).

- (3) *kare-ni sono gakusei-ga wakaru.*
 he-to that student -NOM understand
 'He understands that student.'

This Nominative NP, however, cannot support the subject honorification morpheme *o...ninaru*, which is normally triggered when a respected person is the subject of the sentence.

(4)a. Sensei -ni sono gakusei-ga o -wakari -ninaru.

teacher-to that student-NOM Hon-understand-Hon.

'The teacher(hon) understands(hon) that student.'

b. *Kare-ni sensei-ga o -wakari -ninaru.

he -to teacher-NOM Hon -understand-Hon

'He understands(hon) the teacher(hon).'

The contrast in (4) shows that the subject property which triggers Nominative Case marking is different from the one which triggers subject honorification. Thus, there is a mismatch between the subject properties when the verb is stative, as noted by Harley. Given this mismatch in Japanese statives, it seems reasonable to question the validity of the assumption that the notion "subject" is a unified one and that all "subjects" are generated in the same syntactic position.

1.1.3 Problems and proposals

As noted above, there are at least two main questions concerning the subject position, namely:

i) which position is the base subject position?

and

ii) is the notion of a single subject position adequate?

This thesis will attempt to provide answers to these questions, based on evidence mainly from Japanese. Specifically, we will argue for the following five proposals:

Firstly, there is a functional head Pr generally projected above VP. When the verb is

stative, however, Pr is not present.

Secondly, there are two subject positions, one VP-external and the other VP-internal. The VP-external subject, which is generated in Spec of PrP, is assigned a theta role by the V-Pr complex. The VP-internal subject is generated in Spec of VP when a verb is stative, and assigned a theta role by the verb.

Thirdly, Pr plays a crucial role in realizing event structure, allowing an NP which denotes the beginning of an event to be generated in its Spec as a subject.

Fourthly, it is the functional head Pr, and not V, which is the Accusative Case-bearing head (at least in Japanese). Sentences containing a stative verb, which lack Pr, do not mark the object with Accusative Case, but rather with Nominative.

Fifthly, causativization involves the projection of a second PrP, which introduces an initiator NP to cause a core event. This process produces a structure that has a causer in Spec of the upper PrP.

1.2 Framework

1.2.1 Split INFL hypothesis

This thesis is developed within the Principle and Parameters framework of Chomsky (1986, 1991 & 1992). In this section we summarize key assumptions of this framework regarding clause structure and Case assignment, namely the split INFL hypothesis (Pollock 1989, Chomsky 1991) and feature checking theory (Chomsky 1992).

We assume the split INFL hypothesis proposed by Pollock (1989) and extended by Chomsky (1991), although we make a slight modification later. According to Chomsky's version, a clause has the following structure:

(5)

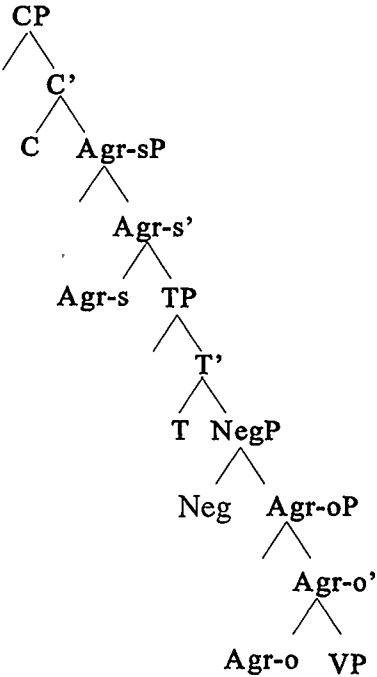

In Pollock, it was proposed that IP be separated into two projections, T(ense)P and Agr(eement)P, reflecting the dual nature of the category INFL. Chomsky then noted that AgrP could also be analyzed as the category associated with object agreement, drawing on Kayne's (1989) analysis of object agreement for French past participles. To unify Pollock's and Kayne's analyses, Chomsky proposed a second AgrP projection above TP. Thus, Agr-s and Agr-o are responsible for Nominative Case and Accusative Case respectively, and T is responsible for tense elements¹.

¹ Although we assume the split INFL hypothesis, we will use IP as an abbreviation for inflectional projections in a diagram for ease of exposition, unless it is critical for our argument to be more specific.

1.2.2 Feature checking theory

Closely related to the split INFL hypothesis is the feature checking theory proposed by Chomsky (1992), which we also assume for purpose of this thesis. In this theory, structural Case is a manifestation of a spec-head relation in AgrP, which is uniformly realized at LF. The subject and object NPs raise to Spec of Agr-sP and Agr-oP respectively to check their Case features. The Nominative Case features are checked off against N-features of T through the spec-head relation, and the Accusative Case features are checked off against N-features of V. Similarly, agreement features of the subject and object NPs are matched against those of V through the spec-head relation. Since Case and agreement are matched only through functional categories, the subject and object NPs which are base-generated in the VP must raise to the Spec position of the functional categories, and V and T must adjoin to the Agr categories either overtly or covertly. According to Chomsky, presence or absence of overt movement of the subject and object NPs to Spec of AgrP and of V and T to Agr is parameterized, depending on the properties of functional heads. In English, for example, the agreement features of Agr are weak, while the Case features of T are strong. Thus, the subject raises overtly to check off the strong Case features of T in English. However, the object does so covertly, because the weak agreement features of Agr do not require checking until LF.

1.3 Basic Sentence Structure and Case Marking in Japanese

In this section we will provide a brief description of the major characteristics of Japanese syntax. The discussion will focus on sentence structure, scrambling and Case-marking.

1.3.1 Sentence structure and scrambling

Japanese is an SOV language in which the basic word order of transitive sentence is subject, object and then verb. The order of the subject and the object is not very rigid. The position of adjuncts is also quite free. The position of the verb, however, is strictly sentence final. All the following examples are grammatical and have the same interpretation:

(6)a. Tom-ga sushi-o isoide tabeta

Tom-NOM sushi-ACC quickly ate

'Tom ate sushi quickly.'

b. Sushi-o Tom-ga isoide tabeta.

c. Isoide sushi-o Tom-ga tabeta

d. Isoide Tom-ga sushi-o tabeta.

This relatively free ordering of constituents is due to leftward constituent movement, a process known as scrambling. The landing site of constituents in clause-internal scrambling is generally considered to be an IP-adjoined position (Saito 1985, Hoji 1985). More recently, assuming the split INFL hypothesis, some linguists including Nemoto (1993) and Watanabe (1993) have suggested that scrambling of arguments constitutes overt movement to Spec of Agr-sP or Spec of Agr-oP, following Mahajan (1990).

Although scrambling allows fairly free ordering, the order of the head relative to nonhead elements is fixed. As indicated by the verb-final constraint, Japanese is a head final language, and nonhead constituents always precede the head of the phrase; a noun phrase precedes a postposition (there are no prepositions) in PP, an adverb precedes the adjective or verb it modifies, and all noun modifiers including PP, AP, VP and relative clauses precede the head in NP.

1.3.2 Case Marking

Case-markers are realized as postpositional particles. Case-marking follows the Nominative-Accusative pattern, with the subject of both transitive and intransitive clauses being generally marked by the particle *ga*, and the object of a transitive clause by *o*. The indirect object is marked by *ni*. The following example illustrates the Case-marking system.

(7) Tom-ga sushi-o Mary-ni yatta.

Tom-NOM sushi-ACC Mary-DAT gave

'Tom gave Mary sushi.'

ni is generally labelled a Dative marker, but the distinction between a Dative Case marker and a postposition, which is also *ni*, is controversial. I will discuss this issue in 4.4.3.

1.4 Organization of the Thesis

The remainder of this thesis is organized as follows. Chapter 2 examines subject positions and proposes a functional projection, Predicate Phrase, which introduces a subject. One of the primary goals of this chapter is to suggest a new subject position, which accommodates the evidence for the [Spec, IP] Subject Hypothesis and for the [Spec, VP] Subject Hypothesis, yet avoids problems associated with these conflicting hypotheses. We will see that Predicate Phrase, in Spec of which a subject is generated, is in fact responsible for projecting an event structure onto syntax by denoting the beginning of an event.

Chapter 3 provides independent evidence for this new subject position based on an analysis of VP-preposing. We review analyses which attempt to account for VP-preposing

assuming the Internal Subject Hypothesis, but we show that evidence from VP-preposing in Japanese tends to support the VP-external subject position.

Chapter 4 deals with stative verbs in Japanese. Stative verbs in Japanese do not undergo VP-preposing. We account for the blocking of VP-preposing by proposing that the subject of stative verbs occupy a different position from the subject of other verbs, namely Spec of VP. We also attempt to demonstrate that Predicate Phrase is responsible for Accusative Case, and attribute the Nominative Case marking on the object NP of a stative verb to the absence of this functional projection.

Chapter 5 analyzes the Japanese causative construction. We suggest that the causative morpheme is base-generated as the head of PrP, and that causativization involves the addition of a second Predicate projection to a core event, introducing a causer or an initiator of a causing event.

Chapter 6 concludes the discussion.

CHAPTER 2

SUBJECT POSITION AND A FUNCTIONAL PROJECTION PrP

In this chapter, we will propose the [Spec, PrP]¹ Subject Hypothesis, wherein the subject is generated in Spec of a functional projection, Pr(edicate) phrase which is located between IP and VP. We will propose that Pr plays a critical role in the event structure of the clause because it introduces the subject which identifies the beginning of the event. In section 2.1 we review the [Spec, IP] Subject Hypothesis and the [Spec, VP] Subject Hypothesis briefly. In section 2.2 we summarize two arguments in favour of the [Spec, VP] Subject Hypothesis. In section 2.3 we discuss three pieces of evidence counter to the [Spec, VP] Subject Hypothesis. In section 2.4 we propose a functional projection Pr and the [Spec, PrP] Subject Hypothesis to accommodate all pieces of evidence we see. In section 2.5 we demonstrate that our hypothesis is compatible with the evidence which initially motivated the [Spec, VP] Subject Hypothesis. In section 2.6 we examine the semantic properties of Pr, suggesting that Pr introduces a subject which denotes the beginning of an event. Finally in section 2.7 we present concluding remarks.

2.1 [Spec, IP] Subject Hypothesis and [Spec, VP] Subject Hypothesis

Various proposals have been made for some kind of asymmetry between the subject of a sentence and the other arguments. Most linguists generally agree that the thematic role assigned to the subject must somehow be set apart from the other thematic roles. Under a

¹ [Spec, XP] is to be read as Spec of XP throughout this thesis. These formulations are used interchangeably.

singled out lexically, and projected onto an NP which is base-generated outside VP. Under the [Spec, IP] Subject Hypothesis, a transitive sentence such as *John cut the orange* has the following D-structure:

(1)

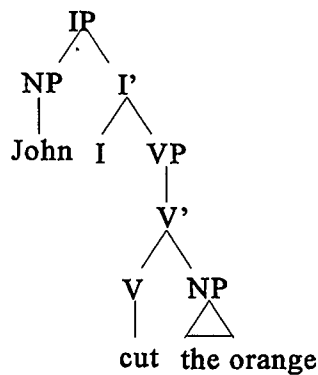

The subject is generated outside the VP in the Spec position of the functional category IP and other arguments are generated inside the VP.

The [Spec, VP] Subject Hypothesis has been advanced in the literature since the mid-1980's (Kitagawa 1986, Fukui and Speas 1986, Kuroda 1988, Koopman and Sportiche 1991, among others). According to this hypothesis, subjects of transitive and intransitive verbs are base-generated in Spec of VP, and raised to Spec of IP for reasons of Case. On this view, the transitive sentence *John cut the orange* is assumed to have the following D-structure:

(2)

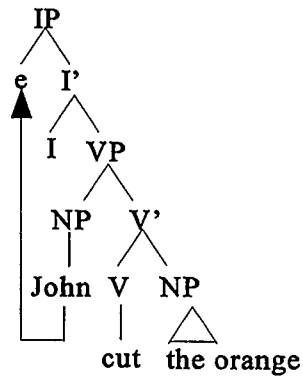

Most empirical evidence presented in the literature in favour of the [Spec, VP] Subject Hypothesis suggests that there is a node lower than Spec of IP, which is associated with the subject. In the following subsection, we will summarize two of the arguments advanced for the [Spec, VP] Subject Hypothesis.

2.2 Arguments for the [Spec, VP] Subject Hypothesis

2.2.1 Quantifier floating (Sportiche 1988)

One well-known argument for the [Spec, VP] Subject Hypothesis is given by Sportiche (1988), based on the distribution of floating quantifiers in French. Assuming that floating quantifiers originate in an NP-initial position, Sportiche argues that these indicate the underlying position of the subject, or positions which the subject moves through. In (3) the floating quantifier *tous* indicates the original subject position.

- (3) Les enfants verront tous ce film.
 the children see-Fut all this film.
 'All the children will see this movie.'

(=(2) p.426, Sportiche (1988))

Since there is independent evidence to show that finite verbs are raised to I overtly in French, Sportiche concludes that subjects must be base-generated in a position, which is within VP. As shown in (4), the subject NP is generated in the position of *tous* and raises into Spec of IP, and the verb raises to INFL, deriving the surface order of subject, verb and quantifier.

(4)

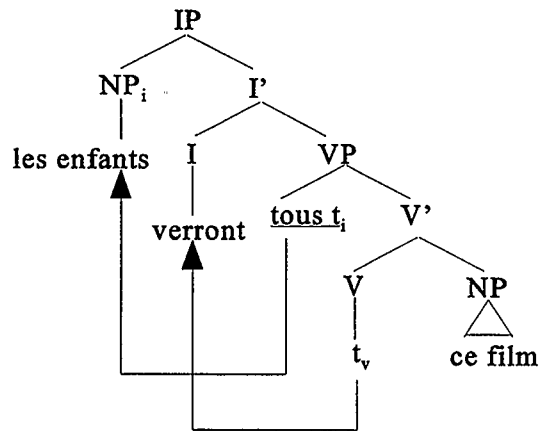

2.2.2 VP Coordination (McNally 1992, Burton and Grimshaw 1992)

Another argument in favour of the [Spec, VP] Subject Hypothesis is based on the coordination of active and passive verbs. McNally (1992) and Grimshaw and Burton (1992)

independently demonstrate that assuming Spec of IP is a derived position resolves a contradiction associated with VP coordination in sentences such as (5).

(5) a. The boys will write a book and be awarded a prize for it.

b. The criminal will be arrested and confess to the crime.

(=(3)p.307, Burton and Grimshaw (1992))

Under the [Spec, IP] Subject Hypothesis, (5b) has the structure given in (6).

The [Spec, IP] Subject Hypothesis:

(6)

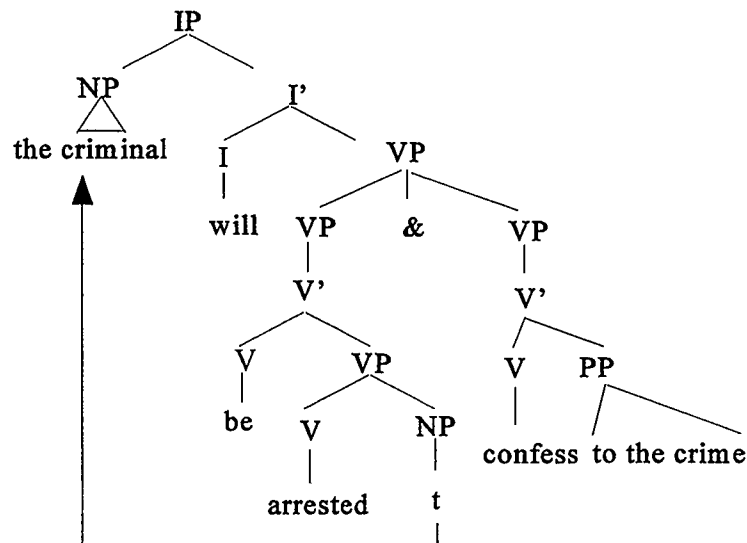

This coordinated structure in (6) violates two standard assumptions. Firstly, it violates the Coordination Structure Constraint (Ross 1967), which prevents movement from one conjunct

in a coordinated structure without parallel movement from the other conjunct. Secondly, the conjunction of two phrases makes the surface subject position simultaneously a theta and theta-bar position. Both McNally and Burton and Grimshaw suggest that if the subject is generated within the VP in active sentences as well as in passive ones, the Coordinate Structure Constraint will be satisfied, and the theta/theta-bar conflict will be resolved. The relevant structure for (5b) under the [Spec, VP] Subject Hypothesis is shown in (7)².

The Internal Subject Hypothesis

(7)

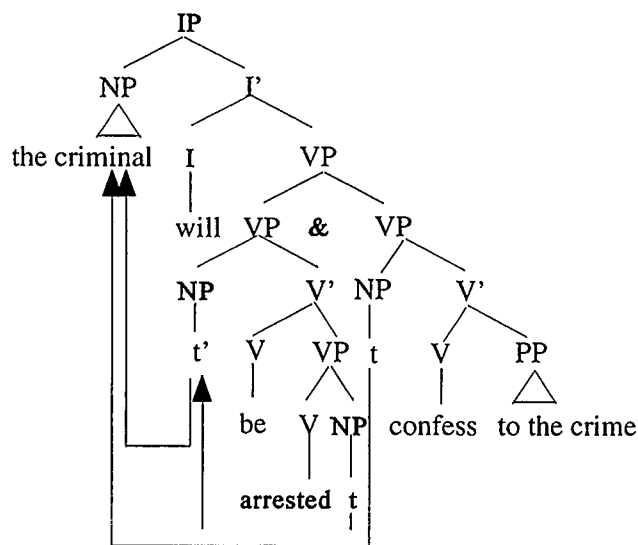

² The internal argument in the passive phrase may move directly from the complement position to Spec of IP, not through Spec of VP, as the direct movement does not violate the theory of movement. The internal argument receives its theta role in the complement position, and does not need to stop at Spec of VP, as the only motivation for the movement is to acquire Case in Spec of IP. The direct movement does not violate the Coordinate Structure Constraint either, as it does not require that the extracted elements be in exactly parallel positions (Williams 1978, p.34 and Burton and Grimshaw 1992, p.309). However, following Burton and Grimshaw I assume the two-step movement of the internal argument in the passive phrase.

This structure shows parallel movement from each conjunct. In the passive phrase, the internal argument is base-generated in the complement position of the verb, and raises to the Spec of VP and then to Spec of IP. In the active phrase, the external argument raises from Spec of VP to Spec of IP. Thus, the surface subject *the criminal* has moved from Spec of VP to Spec of IP in both VPs, obeying the Coordinate Structure Constraint. This derivation involves no theta/theta-bar conflict because Spec of IP is uniformly a theta-bar position; a theta role is assigned to the NP in the complement position in the passive phrase and to the NP in Spec of VP in the active phrase. Thus, the [Spec, VP] Subject Hypothesis resolves the problems associated with the coordination of active and passive verbs under the [Spec, IP] Subject Hypothesis.

2.3 Counterevidence to the [Spec, VP] Subject Hypothesis

In the previous section we reviewed two arguments in favour of the [Spec, VP] Subject Hypothesis. Since the early 1990's, several problems with the [Spec, VP] Subject Hypothesis have been noted in the literature. In this section we will review two arguments that challenge the [Spec, VP] Subject Hypothesis, one presented by Johnson (1991) and the other by Nakamura and Koizumi(1991), both of which suggest that the subject is in fact generated outside VP. We will also introduce a new piece of evidence from Japanese, which shows that asymmetry in subject scrambling over adverbial phrases can be predicted only if we assume that subjects are base-generated in a position below Spec of IP but above VP.

2.3.1 Problems with the Adjacency Condition (Johnson 1991)

Johnson (1991) develops an argument against the [Spec, VP] Subject Hypothesis based on problems associated with the Adjacency Condition. The contrast between (8) and (9) has been traditionally attributed to Stowell's (1981) Adjacency Condition, which requires that Case assigners be adjacent to the NPs which they Case-mark.

- (8) a. *Mike visited quietly his parents
 b. *Betsy sung loudly the anthem.
 c. *Chris hit quickly the dog.
- (9) a. Chris walked quickly down the street.
 b. Michael talked slowly to Gary.
 c. Betsy spoke loudly with everyone.

(=(5&6)p.580, Johnson(1991))

Assuming the Adjacency Condition, in (8) the verb is not able to Case-mark the direct object NP because there is an intervening adverb between it and the NP. Hence (8) is ungrammatical. The examples in (9) pose no problem for the Adjacency Condition because indirect object PPs do not need to be Case-marked. Thus, (9) is grammatical in spite of the presence of an intervening adverb.

Pesetsky (1989), Johnson (1992) and Bowers (1993) note that there is empirical evidence against such an analysis. For example, the adjacency requirement is not true cross-linguistically. French allows the intervention of an adverb between a verb and its object, as shown in (10).

(10) Jean parle souvent le français

Jean speaks often French

Here, the adverb freely appears between the verb and the object. Moreover, adjacency is not a general requirement for Case assignment. The assignment of Nominative Case does not require INFL to be adjacent to the subject even in English, as shown in (11) where the subject NP *Chris* and its Nominative Case assigner INFL are separated by the adverb *certainly*.

(11) Chris certainly will win the game.

Johnson (1991) reasons that if adjacency is not relevant to the assignment of Accusative Case in languages like French or to the assignment of Nominative Case in English, then adjacency is not a condition on Case assignment, and develops an alternative account of the contrast between (8) and (9). Specifically, Johnson postulates an unidentified functional head μ and proposes the following structure:

(12)

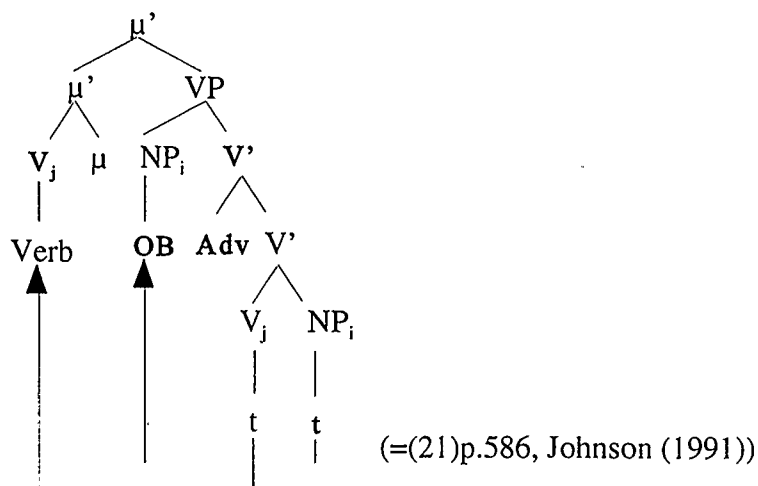

In his proposal, (i) an object NP is generated as a sister to the verb, and moves into Spec of VP to be Case-assigned by μ ; (ii) an adverb may adjoin to V' but not to VP; and (iii) V adjoins to the functional head μ . Advancing the insight of Pesetsky (1989), Johnson accounts for the contrast in (13) by invoking overt movement of the verb and the direct object.

(13)a.*Chris hit quickly the dog.

b. Chris hit the dog_i quickly t_i.

c. Mikey talked slowly to Gary.

The example (13a) is ungrammatical because the object NP has not moved to Spec of VP in order to be assigned Case by μ as it has in (13b). The example (13c) is grammatical because the complement PP does not need to move for Case.

Johnson does not mention specifically where subjects are generated in the proposed structure, but clearly the [Spec, VP] Subject Hypothesis is not compatible with his analysis: Spec of VP is always reserved for object NPs, and subjects must be generated elsewhere. In section 2.4 below we develop a proposal which addresses this problem.

2.3.2 Time phrases: Nakayama and Koizumi (1991)

The next piece of evidence for the VP-external subject position comes from Nakayama and Koizumi (1991), who examine the relative position of the subject, the object and a temporal adverbial phrase, with respect to the interpretation of quantifier scope.

Japanese has a cleft construction similar to the English pseudo-cleft.

(14)a. Tom-ga piza -o taberu.

Tom-NOM pizza-ACC eats.

'Tom eats pizza.'

b. [Tom-ga suru-no-wa] [piza -o taberu-koto-da].

Tom-NOM do -N-TOP pizza-ACC eat -N-COP³.

'What Tom does is eat pizza.'

(14) is an example of pseudo-clefting of VP in Japanese. In this example the object and the verb appear in the 'focus' position on the right, and the subject and *suru* 'do' occur in the presupposed position which precedes the focus position. When a sentence has an indirect object, the indirect object must be clefted together with the object and the verb, as shown in (15).

(15)a. John-ga kaisha -ni tegami-o okutta.

John-NOM company-to letter -ACC sent

'John sent a letter to the company.'

b. [John-ga shita-no-wa] [kaisha -ni tegami-o okutta-koto-da].

John-NOM did-N-TOP company-to letter -ACC sent -N -COP.

'What John did was send a letter to the company.'

c.*[John-ga kaisha -ni shita-no-wa] [tegami-o okutta-koto-da].

John-NOM company-to did -N-TOP letter -ACC sent -N-COP.

'What John did to the company was send a letter.'

(=(8)p.307, Nakayama and Koizumi (1991))

³ N and COP are abbreviations of Nominalizer and Copula.

In (15b), the indirect object *kaisha* 'company' occurs with the direct object and the verb in the 'focus' position, while in (15c) the indirect object appears with the subject. Nakayama and Koizumi attribute the ungrammaticality of (15c) to the fact that the indirect object forms a constituent with the direct object and the verb, and cannot move out of this constituent to appear with the subject in the presupposed position. The fact that the indirect object, but not the subject, is obligatorily clefted in this construction suggests that the subject is not part of the VP constituent.

Nakayama and Koizumi further demonstrate that a temporal adverb such as *2-ji-ni* '2 o'clock' may optionally undergo clefting, as shown below. (16a) is an example without clefting. In (16b), the adverb remains with the subject, while the object and the verb are in the focus position. In (16c), the time adverb is clefted with the object and the verb.

(16)a. Gakusei-ga 2-ji -ni piza -o tabeta.

student-NOM 2-o'clock-at pizza-ACC ate.

'The students ate pizza at two o'clock.'

b. [Gakusei-ga 2-ji -ni shita-no-wa] [piza -o taberu-koto-da].

student-NOM 2 o'clock-at did -N-TOP pizza-ACC eat -N -Copula.

'What the students did at two o'clock was eat pizza'

c. [Gakusei-ga shita-no-wa] [piza -o 2-ji -ni taberu koto-da].

student-NOM did-N-TOP pizza-ACC 2 o'clock at eat -N -Copula.

'What the students did was eat pizza at two o'clock.'

According to Nakayama and Koizumi, the optionality suggests that a temporal adverb is a VP-adjunct. They assign the sentence in (16a) the structure shown in (17). Clefting may involve either the smaller VP or the larger VP, i.e. a VP-adjoined adverb is optionally part of a clefted VP, giving two options for VP-clefting. In (16b), the lower VP is clefted, while

in (16c), the upper VP is clefted.

- (17) Gakusei-ga [_{VP} 2-ji -ni [_{VP} piza-o tabeta]].
 student -NOM 2 o'clock at pizza-ACC ate.
 'The students ate pizza at 2 o'clock.'

Nakayama and Koizumi then examine the relative positions of the subject, the object and the temporal phrase, using quantifier scope interpretation. They assume the Rigidity Condition (18) which was originally proposed by Hoji (1985):

- (18) When two quantified NPs are in their D-structure positions at S-structure, the quantified NP that c-commands the other takes wide scope with respect to the other.

The scope interpretations in (19) show that the subject c-commands the temporal adverb, and the temporal adverb c-commands the object.

- (19)a. Gakusei-ga [2-ji ka 3-ji] -ni [subete-no piza -o] tabeta.
 student-NOM 2 o'clock or 3-o'clock-at all -GEN pizza-ACC ate
 'The student ate all slices of pizza at two or three o'clock.'
- b. Daremo-ga [2-ji ka 3-ji] -ni piza -o tabeta.
 everyone-NOM 2 o'clock or 3-o'clock-at pizza-ACC ate
 'Everyone ate the pizza at two or three o'clock.'

Both (19a) and (19b) have unambiguous readings; the temporal phrase takes wide scope over the object 'all slices of pizza' in (19a), and the subject 'everyone' takes wide scope over the temporal phrase in (19b). Assuming the Rigidity Condition, these scope interpretations

indicate that the subject asymmetrically c-commands the temporal phrase, and the temporal phrase asymmetrically c-commands the object. Moreover, assuming that the temporal phrase is a VP-adjunct, (19) provides additional evidence that the subject is outside VP.

2.3.3 VP-adjoined phrases and scrambling in Japanese

In the preceding two subsections, we summarized arguments against the VP-internal subject position from the literature. In this section, we introduce a new piece of evidence from Japanese which shows that subjects are base-generated outside VP but below IP.

As mentioned in 1.3.1, Japanese has a type of leftward movement, called scrambling, which allows relatively free movement of constituents. An example of object scrambling is shown in (20).

(20)a. Tom-ga Piza-o tabeta.

Tom-NOM Pizza-ACC ate.

'Tom ate pizza.

b. Piza-o_i Tom-ga t_i tabeta.

The object NP *piza* moves past the subject NP to the sentence initial position. Following Mahajan (1990) and Watanabe (1993), we assume that scrambling of the subject and the object in Japanese constitutes overt movement to Spec of IP.

In Japanese, a numeral quantifier (NQ) consisting of a number and a classifier may modify an NP, as shown in (21).

(21) Tom-ga [Piza-o 3-mai] tabeta.

Tom-NOM Pizza-ACC 3-CL ate.

'Tom ate three pieces of pizza.

In (21) the quantifier *3-mai* modifies the object NP *pizza*. When a sentence has a numeral quantifier modifying an NP, scrambling of the NP may leave the numeral quantifier in the base position (see Miyagawa 1989, Terada 1990, Ueda 1990, and Nakayama and Koizumi 1991). In (22b) and (23b) the object NP and the numeral quantifier *3-mai* are separated by a subject and by an indirect object, respectively.

(22)a. Tom-ga [pizza -o 3-mai] tabeta.

Tom-NOM pizza-ACC 3-CL ate

b. Piza-o_i Tom-ga [t_i 3-mai] tabeta.

(23)a. Yuriko-ga Tom-ni [pizza-o 3-mai] ageta.

Yuriko-NOM Tom-DAT pizza-ACC 3-CL gave

Yuriko gave three pieces of pizza to Tom.

b. Yuriko-ga piza-o_i Tom-ni [t_i 3-mai] ageta.

These examples show that the object NP can scramble, stranding the numeral quantifier in the base position.

It has been noted that scrambling of the subject is not as free as that of other NPs. (24) and (25) are grammatical examples of subject scrambling, and (26)-(29) are ungrammatical ones. ((24),(25) and (27) are taken from Ueda (1990 pp.89-90) with modification in word selection for consistency with the previous examples.)

(24)a. Unwaruku [gakusei-ga 2-ri] kussata piza -o tabeta .

unfortunately students-NOM 2-CL rotten pizza-ACC ate.

'Unfortunately, two students ate rotten pizza.'

- b. Gakusei-gai unwaruku [t_i 2-ri] kussata piza-o tabeta
- (25)a. Wazato [gakusei-ga 2-ri] kussata piza -o tabeta
intentionally student-NOM 2-CL rotten pizza-ACC ate.
'Two students intentionally ate rotten pizza.'
- b. Gakusei-ga_i wazato [t_i 2-ri] kussata piza-o tabeta.
- (26)a. Fooku-de [gakusei-ga 2-ri] piza -o tabeta.
fork -by student -NOM 2-CL pizza-ACC ate.
'Two students ate pizza with a fork.'
- b.*Gakusei-ga_i fooku-de [t_i 2-ri] piza-o tabeta.
- (27)a. Gakko-de [gakusei-ga 2-ri] piza-o tabeta.
school-at student-NOM 2-CL pizza-ACC ate.
'Two students ate pizza at school.'
- b.*Gakusei-ga_i gakko-de [t_i 2-ri] piza-o tabeta⁴.
- (28)a. Teineini gakusei-ga 2-ri piza -o tabeta.
Carefully student -NOM 2-CL pizza-ACC ate.
'Two students ate pizza carefully.'
- b.*Gakusei-ga_i teineini [t_i 2-ri] piza-o tabeta.
- (29)a. Suguni gakusei-ga 2-ri eigo -o oboeta
quickly student -NOM 2-CL English-ACC learned
'Two students learned English quickly.'
- b.*Gakusei-ga_i suguni [t_i 2-ri] eigo-o oboeta

All the examples have exactly the same subject movement: the subject crosses over an

⁴ The scrambled sentence with a locative phrase becomes grammatical when it is in the progressive form, as given in Ueda(1990), p.89 (101d). I have no account for this fact.

adverbial phrase to Spec of IP. The only difference is in the choice of intervening elements. In the examples (24) and (25), which are grammatical, the subject and the NQ are separated by a speaker-oriented adverb and a subject-oriented adverb, respectively. The intervening elements in (26)-(29) are an instrumental phrase, a locative phrase, a manner adverb, and a temporal adverb. We argue that the contrast between the grammatical and ungrammatical examples is due to the original positions of these intervening phrases. The chart in (30) summarizes the intervening elements and their base positions. The grammatical elements are grouped as Adv₁ and the ungrammatical elements are grouped as Adv₂.

(30) Intervening element	generated position	
Adv ₁		
a. speaker-oriented adverb	sister to I	(Sportiche 1988) ⁵
b. subject-oriented adverb	between I and VP	(Sportiche 1988)
Adv ₂		
c.*instrumental phrase	VP-adjunct	(Miyagawa 1989)
d.*locative phrase	VP-adjunct	(Miyagawa 1989)
e.*manner adverb	VP or V-adjunct	(Sportiche 1988)
f.*temporal adverb	VP-adjunct	(Bowers 1993)

These facts cannot be explained under the [Spec, VP] Subject Hypothesis. However, they receive a natural explanation if we assume that the subject is base-generated in Spec of an inflectional projection below IP. The structure of (24)-(29) would look like (21) under the

⁵ Sportiche (1988) does not assume the split IP. Thus, the exact location of sentential and subject-oriented adverbs under the split IP hypothesis is not clear. However, this point is not critical to our present argument.

[Spec, VP] Subject Hypothesis.

(31)a.

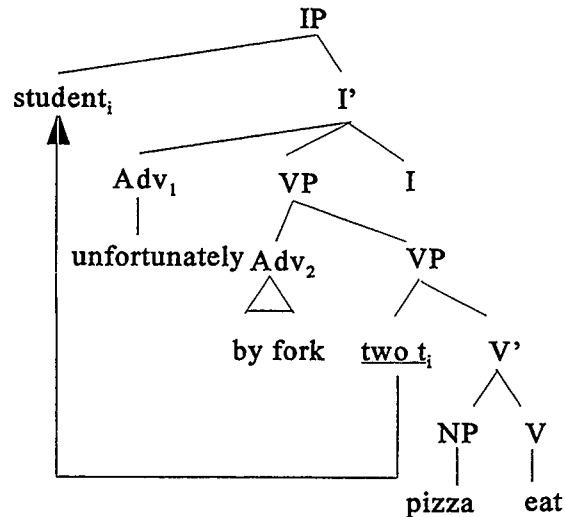

b. Gakusei-ga unwaruku 2-ri kussata pizza -o tabeta
 student-NOM unfortunately 2-CL rotten pizza-ACC ate.

'Unfortunately, two students ate rotten pizza.'

c. *Gakusei-ga, fooku-de [t_i 2-ri] pizza -o tabeta.
 student-NOM fork -by 2-CL pizza-ACC ate.

'Two students ate pizza with a fork.'

Following Sportiche (1988), Adv_1 is as a sister to I , while Adv_2 is adjoined to VP, both originating in a position higher than the subject. In this configuration, the contrast between the grammatical and ungrammatical instances of subject scrambling in (31b) and (31c) cannot be predicted; the subject 'student' should be able to scramble over Adv_1 as well as Adv_2 . If there are more functional projections dominating VP, there are additional Spec

positions available to the subject. Recall Johnson (1991)'s proposal which we discussed in 2.3.1. He postulated an unidentified functional μ phrase above VP. If we adopt his structure, we are able to place the subject between Adv_1 and Adv_2 and account for the asymmetry in subject scrambling exhibited in (31). (32) below illustrates the structure of (31b-c), adopting Johnson's μ phrase.

(32)

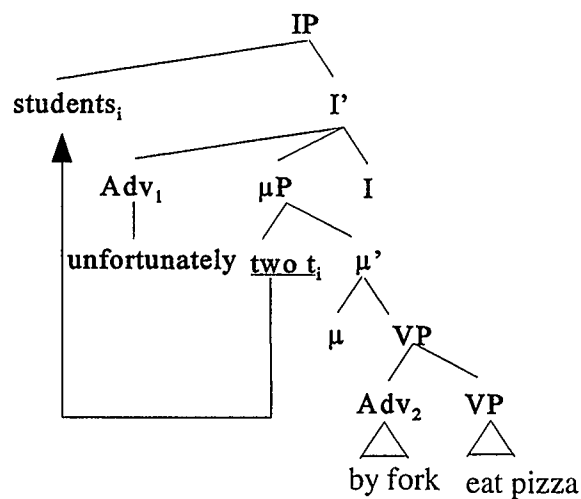

The subject is now in Spec of μP between Adv_1 and Adv_2 . In the grammatical examples, the subject moves to Spec of IP, but Adv_1 is *in situ*. In the ungrammatical examples, both the adverb and the subject have moved. The adverb adjoins to IP, and the subject moved from Spec of μP through Spec of IP to Spec of CP, as (33) shows.

(33)

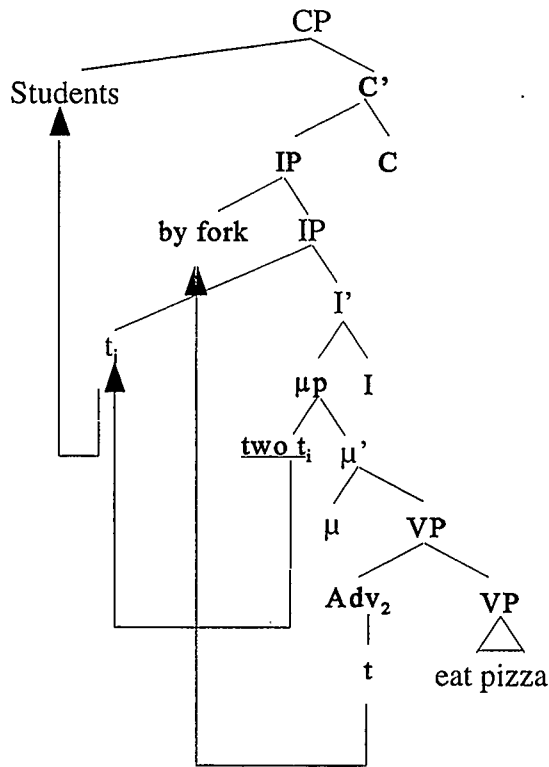

This structure permits an explanation of the ungrammatical examples. To scramble over Adv_2 from Spec of μP , the subject must undergo two movements from Spec of μP through Spec of IP to Spec of CP, after Adv_2 adjoins to IP⁶. The first movement of the subject is grammatical, but the second one is not, because the Spec of CP is reserved for the topic and Wh-constituents only. Thus, the ungrammatical examples are correctly ruled out.

In this section we have shown that the asymmetry in subject scrambling over adverbial phrases can be explained only if we assume that the subject is generated above the VP-adjoined adverb. The subject position must be below IP as well, if we assume that scrambling moves the subject to Spec of IP.

⁶ The assumption that Adv_2 adjoins to IP, not to μP , is crucial to our argument.

2.4 [Spec, PrP] Subject Hypothesis

In the previous subsections, we saw three pieces of evidence for a subject position above VP. The first piece of evidence was based on the problems of adjacency requirement on Case assignment. The second piece of evidence came from the relative positions of the subject, the object and the temporal phrase, with respect to the interpretation of quantifier scope in Japanese. The third piece of evidence came from the asymmetry in subject scrambling over adverbial phrases in Japanese. This evidence also indicated the presence of a functional projection below IP but above VP, which we tentatively called μ P. The evidence presented here can be accommodated if we assume that the functional projection μ P constitutes part of the syntactic structure of the clause. More specifically, we adopt a modified version of Bower's proposal that clauses include a functional projection, Predicate Phrase (PrP).

Bowers proposes a structure with an extra functional projection, Predicate Phrase, which has the semantic function of predication. The subject is base-generated inside Predicate Phrase, i.e. outside VP but below Spec of IP. The structure we adopt is shown in (34).

(34)

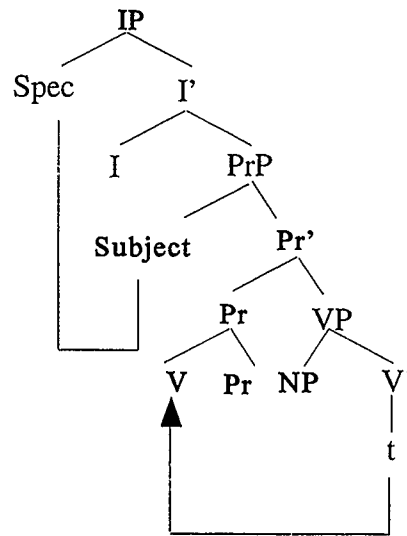

The functional category PrP is projected above VP but below IP. The subject is generated in Spec of PrP.

Differing from Bowers, we will propose that a theta role is assigned by the verb in conjunction with Pr to the subject. Bowers assumes that the verb substitutes into Pr, and assigns a theta role to the subject through the spec-head relation. However, we assume that the verb adjoins to Pr, because Pr is filled with an abstract element, which we will motivate in 2.6.

2.5 Evidence for the [Spec, VP] Subject Hypothesis Revisited

We have seen two arguments advanced for the [Spec, VP] Subject Hypothesis in 2.2. In this section, to complete our argument, we will show that they do not constitute counterevidence to our proposal, and that the facts that have been accounted for under the [Spec, VP] Subject Hypothesis can also be explained within the [Spec, PrP] Subject Hypothesis.

2.5.1 Quantifier floating

As discussed in 2.2.1, Sportiche (1988) advocates the [Spec, VP] Subject Hypothesis, arguing that the floating quantifiers indicate the underlying position of the subject, and the position which the subject moves through. In (35(=3)) the floating quantifier *tous* indicates the original subject position.

- (35) [Les enfants]_i verront tous _{t_i} ce film.
 the children see-Fut all this film.
 'All the children will see this movie.'

Since finite French verbs are raised to IP overtly, Sportiche concludes that subjects must be lower than IP, in a position which is within VP in his structure. However, this evidence does not necessarily lead to VP-internal subject position. In Sportiche's structure, VP is dominated by I; therefore the original subject position, which is lower than I, must be located within VP. But if there is another functional category under I, as we assume, the initial subject position can be within the functional phrase, and Sportiche's argument does not contradict our VP-external subject proposal, as (36) illustrates.

(36)

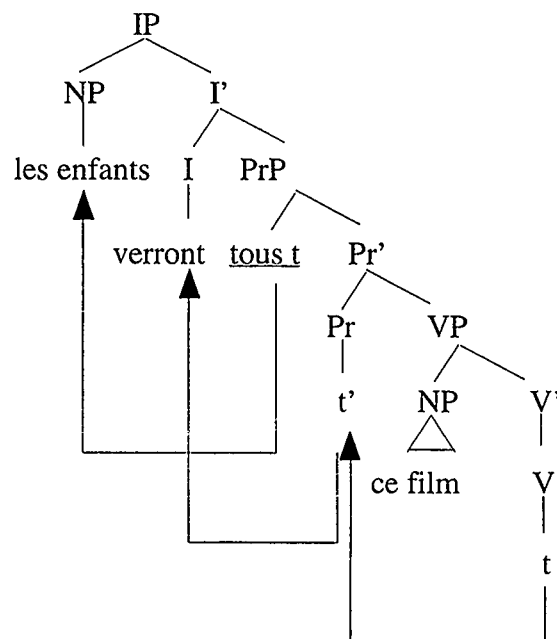

2.5.2 VP Coordination

The second argument for the [Spec, VP] Subject Hypothesis that we discussed was based on coordination of active and passive verbs presented by McNally (1992) and Grimshaw and Burton (1992). They demonstrate that assuming Spec of IP is a derived position resolves a contradiction associated with VP coordination sentences such as (37).

(37(=5b)) The criminal will [[be arrested] and [confess to the crime]].

The structure they propose under the [Spec, VP] Subject Hypothesis is repeated as (38).

(38)

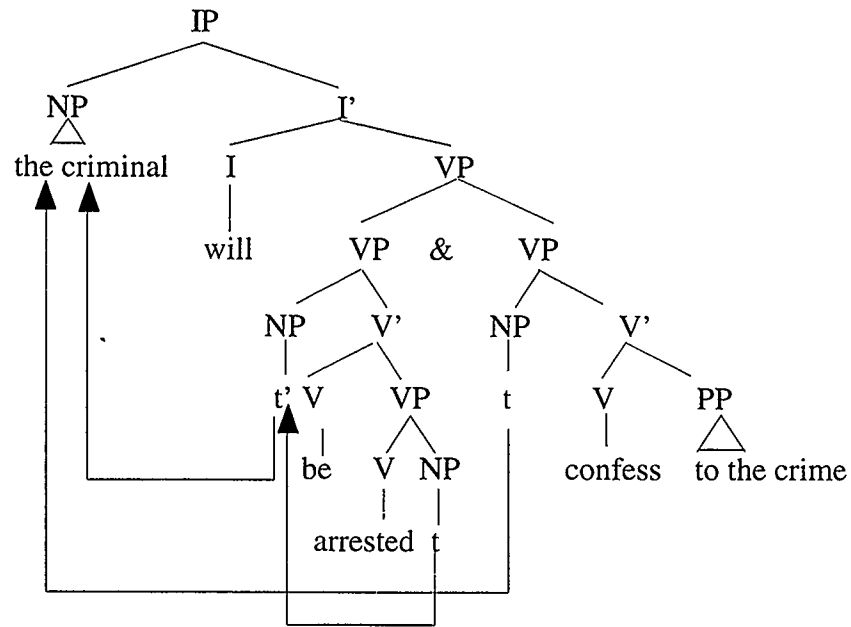

However, this argument is not necessarily counter to our proposal. The structure under the [Spec, PrP] Subject Hypothesis also avoids the problems associated with the coordination of active and passive phrases, as shown below.

(39)

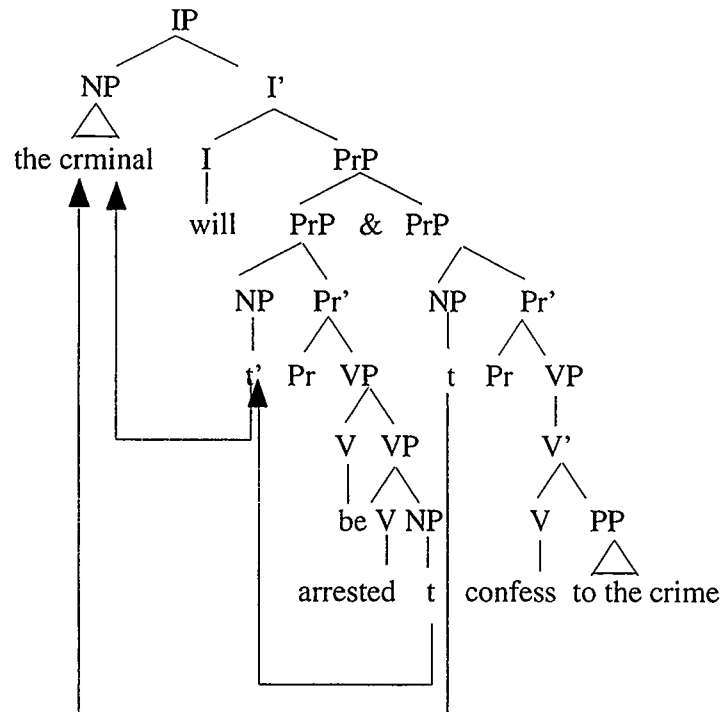

If we assume that the internal argument of the passive moves first to Spec of PrP, and then raises to IP, as the external argument of the active phrase does, the coordinated structure will not violate any principles; the movement from each conjunct satisfies the Coordinate Structure Constraint, and the base-generation of the subject of an active verb in Spec of PrP makes Spec of IP a theta-bar position for both conjuncts.

2.6 The Role of Pr in Event Structure

In the previous sections, we argued that the external arguments are generated in Spec of PrP between IP and VP. Empirical evidence for the existence of an extra projection above VP was discussed in 2.3. In this section we will analyze semantic properties of the projection

Pr, and argue that Pr hosts a subject which denotes the beginning of an event. There have been several recent papers which suggest that a predicate is made up of some kind of an event phrase in combination with a verb. (Kratzer 1993, Pesetsky 1994, Borer 1994, Travis 1994, Harley 1995, and Guilfoyle 1995 among others). Following along the line of these proposals, we propose that Pr maps event structure onto syntax structure. In 2.6.1, we review van Voorst (1988), which we heavily rely on for the analysis of event structure and the relationship between event structure and phrase structure. In 2.6.2 we look at a proposal of Guilfoyle (1995), which argues that an upper V licenses an initiator of an event in Irish, assuming the event structure proposed by van Voorst. In 2.6.3, we examine subjects in Japanese and demonstrate that they have characteristics similar to Irish and Dutch. In 2.6.4, we define a role which Pr plays in projecting an event structure onto the syntax in Japanese. In 2.6.5, we briefly discuss unaccusatives and suggest that unaccusative verbs project Pr, because they are eventive. In 2.6.6, we conclude this chapter.

2.6.1 Event Structure (Van Voorst 1988)

Van Voorst (1988) proposes that events are linear, with a beginning point and an end point denoted by the subject and the direct object NP, respectively, although the actual organization of event structure differs crosslinguistically. These notions are illustrated in (40).

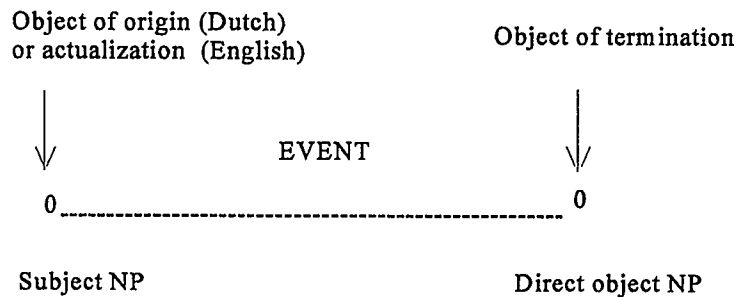
(40) Event Structure Correspondence Rule

(=(20) p.10 Van Voorst (1988))

In both English and Dutch, object NPs denote entities which identify the termination of the event. The entities denoted by subject NPs are used to identify the beginning point of the event, but play a different role in English and in Dutch. In Dutch, subjects are objects of origin, playing an initiating role in an event, while in English they are objects of actualization, not necessarily involved in initiating an event, yet crucial in actualizing it. This contrast is illustrated in (41).

(41)a. The key opened the door. (=(22) p.11, Van Voorst (1988))

b.*De sleutel opened de deur
 the key open-Past the door
 'The key opened the door.'

(=(49) p.37, Guilfoyle (1995))

(41) shows that 'the key' is not an initiator. It is acceptable as a subject in English, because 'the key' actualizes the opening of the door, but not in Dutch, which requires that the subject be an initiator.

Van Voorst further suggests that unaccusative verbs do not select an object of origin

although they do select an object of termination. The latter is generated as the direct object in deep structure, but realized as a derived subject in the surface structure. The scheme in (40) also predicts that the stative verbs are excluded from the event structure, because states, by definition, are neither initiated by an object of origin or of actualization, nor delimited by an object of termination.

2.6.2 Initiator subjects in Irish (Guilfoyle 1995)

Guilfoyle (1995) notes that in Irish, like Dutch, external arguments are always associated with the initiation of event described by the predicate. Guilfoyle, who assumes that a predicate consists of two VPs, an upper VP headed by a light verb and a lower VP headed by a verbal noun, suggests that the upper VP permits an external argument in its Spec position in Irish but only when that argument is the initiator of the event described by the verb of the lower VP. The following contrast illustrates her argument.

(42)a. *D'oscail an eochair an dorais

open-Past the key the door

'The key opened the door.'

b. D'oscail Seán an dorais

open-Past Seán the door

'Sean opened the door.'

(=(44 & 46) pp.37-38, Guilfoyle (1995))

In (42a) 'the key' is an instrument, and does not play a role in initiating the event. When 'the key' is replaced by a person who opens the door, the sentence becomes grammatical. She suggests that the Spec of VP in Irish can only be occupied by the initiator of the event. 'The key' does not play the role of an initiator, thus (42a) is ungrammatical. 'Seán', on the other

hand, is an agent and initiator of the event, and (42b) is grammatical. She further suggests that if a verb does not provide a beginning point for an event such as unaccusative, stative and psychological verbs, Spec of VP is not generated; a theme or experiencer subject does not occupy Spec of VP, but appears as a PP. An example of a stative verb is given in (43).

(43) Tá a fhios agam...

is it knowledge at me...

'I know...'

(=(59c) p.39, Guilfoyle (1995))

The subjects in Japanese have properties similar to Irish; an instrument is not allowed to act as a subject, as shown in (44), which are Japanese equivalents of (42)⁷.

(44)a. *kagi-ga doa -o aketa.

key -NOM door-ACC opened

'The key opened the door.'

b. Tom-ga doa -o aketa.

Tom-NOM door-ACC opened

'Tom opened the door.'

The instrument 'key' cannot act as a subject of the sentence, whereas an initiator or an agent can. The subject of a stative verb may be expressed as a PP, as in Irish, as shown in (45).

(45) John-ni nihongo -ga dekiru.

John-to Japanese-NOM speak-can

⁷ I am grateful to E. Guilfoyle (p.c.) for pointing out the similarity between Japanese and Irish.

'John can speak Japanese.'

(=(25)p.338 Kuno(1973))

In (45) the stative verb has its semantic subject expressed as a PP⁸. We do not assume two VPs, but the similarity of the constraints on subjects seems to indicate that PrP in our proposal and the upper VP in Guilfoyle's play similar roles in the event structure. In next subsection we explore the properties of Pr further.

2.6.3 Initiator subjects in Japanese

As mentioned above, Japanese, like Irish and Dutch, does not allow an instrument to be a subject⁹.

(46(=44))a. *kagi-ga doa-o aketa.

· key-NOM door-ACC opened

'The key opened the door.'

b. Tom-ga doa-o aketa.

Tom-NOM door-ACC opened

'Tom opened the door.'

Similarly, the following examples are not fully acceptable.

⁸ Stative verbs will be discussed in detail in chapter 4, including Case marking and the status of PP arguments.

⁹

Japanese, like Irish, seems to work better than Dutch for van Voorst's analysis.

(47)a. ?Jooheki-ga machi-o kakomu.

wall -NOM town-ACC surround

'The wall surrounds the town.'

b. ?kono hinanjo-ga binboonin-o shuuyou suru.

this shelter -NOM the poor -ACC house

'This shelter houses the poor.'

The examples in (47) become grammatical when an agentive subject is added, and the locative and instrumental NPs are demoted to PPs.

(48)a. Oosama-ga machi-o jooheki-de kakomu.

king -NOM town -ACC wall -by surround

'The king surrounds the town with a wall.'

b. Seifu-ga binboonin-o kono hinanjo-ni shuuyou suru.

government-NOM the poor-ACC this shelter-in house

'The government houses the poor in this shelter.'

The data in (48) indicate that the subject of an eventive verb in Japanese, as in Irish and Dutch, must be the initiator of the event.

When a verb is stative, the 'subject' may be expressed by a PP. In Japanese, subjects are generally marked with the Nominative Case marker *-ga*, and objects are marked with the Accusative Case marker *-o*. When a verb is stative, however, the subject may appear with the postposition *ni*¹⁰, while nominative Case is

¹⁰ The status of the particle *ni* is controversial, but in chapter 4, where the stative construction is discussed in detail, we will provide evidence to support the claim that *ni* in (54) is not a Dative Case marker, but a postposition.

assigned to the object, as shown below.

- (49)a. Tom-ni eigo -ga dekiru.
 Tom-to English-NOM capable to do
 'Tom is capable of English.'
- b. John-ni yama -ga mieru.
 John-to mountain-NOM see
 'John sees mountains.'
- c. John-ni kane -ga aru
 John-to money-NOM have.
 'John has money.'

The subjects of stative verbs in Japanese can alternatively bear a Nominative Case marker, producing a double Nominative structure, as given below. However, when the subject is marked with *ga*, the interpretation changes, as the English translation indicates.

- (50) Tom-ga eigo -ga dekiru.
 Tom-NOM English-NOM capable to do
- (i) 'It is Tom who is capable of English.'
- (ii)*'Tom is capable of English.'

Following Kubo (1992), we will assume that the subject with the interpretation (i) has different syntactic structure from the one with the interpretation (ii), and requires a separate analysis. Thus we exclude the double Nominative structure from our discussion. It suffices to note that the interpretation (ii) prevails in stative structures only when the subject is accompanied by the postposition *ni*. We will return to the stative structure in chapter 4.

2.6.4 Properties of Pr in event structure

In the previous subsection, we saw that the subject of a nonstative verb is an initiator in Japanese, and that the subject of a stative verb with a neutral interpretation appears as a PP, as in Irish. Given these data and Guilfoyle's (1995) analysis, we propose that Pr is essential for the realization of the event; it maps the event structure onto the syntactic structure by introducing the initiator of the event as the subject in Japanese¹¹. Following van Voorst, an event has two endpoints, which are the object of origin or actualization and the object of termination. The event can be seen as movement from the initiation point to the termination point. In the syntactic structure, the object of origin or actualization is denoted by the subject NP and the object of termination is denoted by the direct object NP. However, mapping the concept of the event onto the syntax requires a functional projection Pr, which introduces an initiator or actualizer of the event, the subject. If a clause lacks PrP, the beginning point is not projected onto syntax, and consequently an event interpretation is not obtained. Thus, PrP must be projected when a verb is eventive.

We further suggest that Pr is not generated in stative constructions, which do not constitute an event. We propose that the subject of a stative verb is generated VP internally, as shown below.

¹¹ Borer(1994) and Travis (1994) present similar proposals based on the event structure. Their analyses concern both the beginning and end points of an event, while our discussion is mainly focused on the initiation point.

(51)

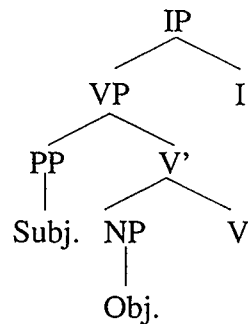

Guilfoyle assumes that in stative construction, the upper VP (which corresponds to our PrP) is present, although Spec of this projection is not generated, but we differ from her on this point. When a verb is non-eventive, Pr has neither event structure to realize nor the object of origin to introduce. Pr is only required for event realization; when a verb does not describe an event, Pr is not present. As a functional projection, Pr is not generated when it has no function to play. Our suggestions for the stative structure (51) seem speculative at present, but we will provide a piece of evidence to support this structure in chapter 4.

2.6.5 Unaccusative verbs

We have proposed that Pr is responsible for the realization of an event. Given our current proposal, we suggest that Pr is projected in the unaccusative construction, because unaccusative verbs are eventive.

One of the crucial differences between stative verbs and eventive verbs is that the former involves no change of state or location. They are property-denoting predicates, and they cannot not be modified by adverbials which express the culmination of an event.

(52)a. *Tom loved his son in five minutes.

b.*Jane knew French in two hours.

In (52), adverbials *in five minutes* and *in two hours* indicate completion of the events, and imply that the state was terminated or completed within a certain length of time. However, a state cannot be completed. Individual level stative predicates are temporally unbounded, and stage level stative predicate have an endpoint, but not a point of termination. They may be stopped, but not completed. Thus, the adverbials expressing the completion point are not possible with stative verbs, because stative verbs cannot be delimited by an object of termination.

By contrast, unaccusative verbs do allow such adverbial modification.

(53)a. The rat died in five minutes.

b. He fell to the ground.

(53a) involves a change of state and (53b) involves a change of location, and they allow modification by adverbs which express a change of location or completion of an event. The grammaticality of (53) indicates that unaccusative verbs such as *explode* or *fall* denote an event, not state.

To be consistent with our analysis presented in section 2.6.4 on eventive verbs, we suggest that unaccusative verbs, which are eventive, project PrP. However, since they lack an external argument, i.e. an object of initiation/actualization, Spec of PrP is unfilled. (54) illustrates the unaccusative structure we assume throughout the thesis.

(54)

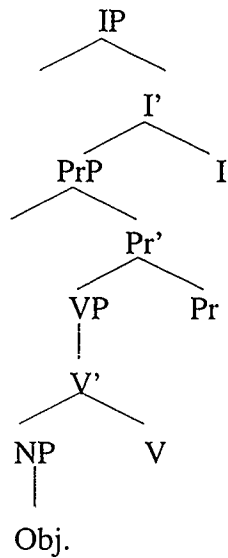

We will come back to this structure in chapter 5, where we discuss causativization.

2.7 Summary

To sum up this chapter, we have concluded that a functional phrase PrP is generated immediately above VP when the verb is nonstative. The external argument of a nonstative verb is generated in Spec of PrP, and any internal arguments are generated inside VP. Pr plays a role in semantic interpretation by mapping the conceptual structure of the event onto the syntactic structure, introducing an entity that denotes the beginning of the event. We have also suggested that stative verbs do not project PrP, while unaccusative verbs project PrP because they are eventive. Spec of PrP in the unaccusative structure is unfilled since it lacks an object of initiation/actualization.

CHAPTER 3

VP-PREPOSING

In the literature, VPs are assumed to undergo preposing as shown in (1).

- (1)a. She may visit her doctor every week.
b. [Visit her doctor every week] she may.

However, exactly which constituent is preposed is controversial. Recently Takano (1995), extending Huang(1993), has argued that reconstruction effects induced by predicate fronting can be accounted for if we assume that the preposed VP constituent contains a trace of the subject, which triggers reconstruction at LF. On the basis of this analysis, he concludes that the [Spec, VP] Subject Hypothesis is crucial to the analysis of VP-preposing.

In this chapter we critically review previous accounts of VP-preposing and Takano's argument. Then we discuss Japanese VP-preposing and demonstrate that Takano's analysis does not provide an account for the ungrammaticality of some preposed structures in Japanese. Based on the asymmetry between Japanese and English in VP-preposing, we propose an alternative account of VP-preposing, where English predicate fronting involves preposing of PrP while Japanese predicate fronting involves preposing of VP. We further suggest that English PrP is reconstructed due to the presence of a subject trace in Spec of PrP, while Japanese VP, which has no subject trace, is not reconstructed. Thus, we will show that the analysis of predicate fronting lends independent support to the [Spec, PrP] Subject Hypothesis which we proposed in chapter 2.

In section 3.1, we describe the syntactic operation of VP-preposing. In section 3.2, we review Takano (1995). In section 3.3, we introduce Japanese evidence on VP-preposing,

section 3.4, we develop an alternative analysis of VP-preposing in order to account for the asymmetry between English and Japanese. In section 3.5, we conclude chapter 3.

3.1 The [Spec, VP] Subject Hypothesis and VP-Preposing

The [Spec, VP] Subject Hypothesis, where a subject is generated VP-internally, is problematic for the analysis of VP-preposing. The feature checking theory assumes that the subject raises to Spec of Agr-sP overtly in English due to the strong Case feature of Tense (Marantz 1994), while the object remains *in situ* before S-structure due to the weak NP feature of Agr. The verb also remains VP internal, as Agr and Tense both have weak V-features in English. If we suppose that VP-preposing occurs before the subject is raised to Spec of TP, then VP-preposing will front the subject argument as well as the verb its internal arguments, as (2).

(2)*[She visit her doctor every week]_i t_i may.

This is not what we expect from VP-preposing. Suppose, instead, that VP-preposing occurs after the subject is raised to Spec of TP. Then the trace of the raised subject will be higher than its antecedent, and fail to be properly antecedent-governed, as shown in (3).

(3) [_{VP} t_i Visit her doctor every week] she_i may.

In this example, the subject trace is not c-commanded by its antecedent, resulting in an ECP violation. Thus, VP-preposing is not theoretically possible, whether the subject is raised prior

to the preposing or afterwards, as long as the subject is generated in Spec of VP¹. Unless the grammaticality of (3) is explained somehow, the [Spec, VP] Subject Hypothesis must be rejected.

3.2 Preposed Constituents

There are two alternatives which avoid the problems associated with VP-preposing under the [Spec, VP] Subject Hypothesis. One is to prepose the V' constituent. The other is to assume that VP-preposing raises the trace of the subject, yet leaves the trace properly governed. We will discuss each alternative in turn.

3.2.1 V'-preposing

Here, we assume that VP-preposing is in fact V'-preposing. VP-fronting only fronts V', leaving the internal subject or its trace *in situ*. In fact, Roberts (1990) takes this approach. But this is not an optimal solution. It may solve the immediate problem by excluding the subject from the movement, but it is a violation of movement constraint: if Move- α applies to X, X must be X^{max} or X^{min}. (Chomsky 1986). If we allow X' to move, we can no longer explain the following grammaticality contrast:

(4) a. [_{DP}The doctor's [_D[_{NP}thorough [_Nexamination of his patients]]]

¹ We assume that the ECP must be satisfied throughout the derivation; the movement of the trace as part of the preposed VP may not violate the ECP, even if the ECP is satisfied prior to such movement.

- b. *Examination of his patients, I regularly praised the doctor's thorough.
- c. The doctor's thorough examination of his patients I regularly praised².

The hypothesis that an intermediate category may move raises a number of questions concerning movement, and given the evidence that no other movement rule applies to the X' level, we will reject this first option.

3.2.2 VP-preposing with a subject trace

The second alternative is to assume that VP-preposing raises the trace of the subject, yet leaves the trace properly governed. As mentioned above, if the subject is raised prior to VP-preposing, VP-fronting will result in raising the trace of the subject, and its antecedent, the subject, will no longer c-command the trace. However, if there is still some mechanism to satisfy the ECP in this configuration, VP-preposing is possible. Takano (1995) takes this approach. Drawing on Huang (1993), he argues that fronted predicates are interpreted in their base positions at LF³.

Huang proposes that the [Spec, VP] Subject Hypothesis can account for the

² In fact there appear to be additional constraints on constituent preposing. Assuming a DP analysis of noun phrase, then the preposed constituent in (i) is in fact a constituent, specifically an NP. The fact that an NP cannot be moved out of its containing DP indicates that there are other considerations involved in determining the applicability of this operation

(i) *Thorough examination of his patients, I regularly praised the doctor's.

³ Takano (1995) suggests two alternatives to trigger the reconstruction, one based on the Proper Binding Condition and the other based on the Chain Condition under the copy theory. We summarize the former alternative only, as our argument against it is also applicable to the latter.

ungrammatical examples shown in (5), where the subject and object are coreferential.

(5) a. *Criticize John_i, he_i did.

b. *How proud of John_i is he_i ? (= (1a&b) p.329, Takano(1995))

Huang assumes that the subject is generated VP-internally and that VP-preposing is actually fronting a functional category PredP dominating VP rather than the VP itself. Under these assumptions, the structure of (5) is shown in (6).

(6) [_{CP} [_{PredP} [_{VP} t_i criticize John_i]]_j, [_{IP} he_i did t_j]].

In this structure, the trace of the subject *he* binds *John* in the fronted predicate; hence the structure violates Principle C of the binding theory. Huang's proposal accounts for the above examples, but the ungrammaticality of the following examples (7) is left unexplained. The structure of (7a) is given in (8).

(7) a. *Criticize a student that John_i taught, he_i said Mary did.

b. *Proud of a student that John_i taught, he_i said Mary is.

(8) [_{PredP} [_{VP} t_j Criticize a student that John_i taught]], he_i said Mary_j did.

In (7), *John* is free, and should not induce a Principle C effect. Note that a structure similar to (7) does not exhibit a Principle C violation, as shown in (9).

(9) a. Which student that John_i taught did he_i say Mary criticized?

b. The student that John_i taught, he_i said Mary criticized.

(9) has a similar structure to (7) with respect to embedding of the R-expression, but does not show a Principle C effect. The contrast between (7) and (9) leads Takano to propose the following generalization:

(10) Fronted predicates are interpreted in their base positions at LF.

(=(14) p.332, Takano (1995))

Given the [Spec, VP] Subject Hypothesis, a fronted predicate contains an unbound trace, as shown in (11b).

(11)a. Criticize John, Bill did.

b. $[_{CP} [_{PredP} [_{VP} t_i \text{ criticize John}]]_j, [_{IP} \text{ Bill}_i \text{ did } t_j]]$

To save the structure, he argues, the reconstruction process is applied. Reconstruction moves the fronted predicate with the unbound trace back to its original position to eliminate that trace⁴. If Takano is correct, the reconstruction will account for the VP-preposing and both the Condition A and C effects accompanying predicate fronting, justifying the [Spec, VP] Subject Hypothesis.

3.3 VP-Preposing in Japanese

Predicate fronting is generally permitted in Japanese. (12) and (13) are canonical word order sentences with a transitive verb.

⁴ see Takano (1995) for complete discussion.

(12) John-wa sushi-o tabe-ta.

John-TOP sushi-ACC eat -Past

'John ate sushi.'

(13) John-wa Jiro to hanashi-ta

John-TOP Jiro with talk -Past

'John talked to Jiro.'

A VP node cannot move in this structure (see Kuno 1978, Saito 1985, and Whitman 1986). However, as Hoji, Miyagawa and Tada (1989) note, if the topic marker *wa* or any of the contrastive markers attach to the end of the VP, an independent auxiliary *suru* 'do' can support a bare VP.

(14) John-wa [sushi-o tabe]-wa -shi-ta⁵

John-TOP sushi-ACC eat -TOP-do-Past

'John did eat sushi.'

(=(30) p.96, Tateishi (1991))

(15) John-wa [Jiro to hanashi]-wa -shi-ta

John-TOP Jiro with talk -TOP-do -Past

'John did talk to Jiro.'

A VP node is then preposed with the help of the auxiliary *suru* as follows:

(16) [[sushi-o tabe]-wa]_i John-wa t_i shi-ta.

sushi-ACC eat-TOP John-TOP do-Past

⁵ *Shi-ta* is the past tense of *suru*.

'Eat sushi John did.' (= (32) p.97, Tateishi (1991))

- (17) [[Jiro to hanashi]-wa]_i John-wa t_i shi-ta
 Jiro with talk-TOP John-TOP do-Past
 'Talk to Jiro John did.'

3.3.1 Three Exceptions to VP-preposing

Tateishi (1991), drawing on Hoji, Miyagawa, and Tada (1989), notes that there are three structures which do not undergo VP-movement: a VP, part of which underwent scrambling (Saito 1986, Hoji, Miyagawa and Tada 1989), a VP in the passive construction and a VP in the unaccusative construction (Tateishi 1991).

Firstly, a VP a part of which is scrambled out independently cannot move, as shown in (18). In (18a) the object *sushi* scrambles out, yielding (18b). Then as (18c) shows, the VP cannot prepose.

- (18)a. John-wa [_{VP} sushi-o tabe]-ta
 John-TOP sushi-ACC eat-PAST
 'John ate sushi.'
- b. Sushi-o, John-wa [_{VP} t_i tabe]-ta.
- c. * [_{VP} t_i tabe]_j-wa sushi-o John-wa t_j shi-ta.

Secondly, a unaccusative VP cannot move. *Ku-ru* 'come' (*ki-ta* is the past form) is an unaccusative verb, (Miyagawa 1989); and as (19) shows, it does not allow VP-fronting.

(19)a. Tom-wa [_{VP} ki] -ta

Tom-TOP come-Past

'Tom came.'

b. * [_{VP} ki]_i-wa Tom-wa t_i shi-ta

(=(6) p.109, Tateishi (1991))

The third exception to such VP movement is the passive structure, as illustrated in (20).

(20)a. John-wa [_{VP} Tom niyotte koros-are] -ta.

John-TOP Tom by kill -Passive-Past

'John was killed by Tom.'

b. * [_{VP} Tom niyotte koros-are]_i-wa John-wa t_i shi-ta.

Hoji, Miyagawa and Tada (1988) and Tateishi (1991) note that all three ungrammatical examples contain a trace left by previous movement. Scrambling involves extraction of a constituent out of the VP at S-structure. Passive and unaccusative structures involve movement of an internal argument to the subject position before SPELL-OUT. All these movements leave a trace VP-internally as the following schematic forms show:

(21)a. Scrambling

Obj_i Subj [t_i V]

b. Unaccusative and Passive

Subj_i [t_i V]

Let us examine a passive sentence more closely. The example in (22) is a grammatical unpreposed passive sentence; (23) is the structure with 'do-support' but no VP movement; and (24) is the structure with the fronted VP. The structure of (24) is schematized in (25)

using Takano's framework.

- (22) John-wa_i [t_i Tom niyotte koros-are] -ta.
 John-TOP Tom by kill -Passive-Past
 'John was killed by Tom.'

- (23) John-wa_i [t_i Tom niyotte koros-are]-wa-shita.
 TOP-did

- (24)*[t_i Tom niyotte koros-are]_j-wa John-wa_i t_j shi-ta.

- (25) [_{PredP} t'_i [_{VP} [_{V'} t_i V]] [_{IP} John_i did]

The subject *John* is generated as an internal argument and undergoes NP-movement to the Spec of PredP, leaving a trace t_i in the base position, and further, raises to Spec of Agr-sP, leaving another trace t'_i . Then the predicate preposes, yielding the surface order illustrated in (24). If LF reconstruction applies to a fronted predicate as Takano claims, the PredP will be put back into its base position, yielding the structure (23) and (24) should be grammatical. However, it is ungrammatical, contrary to Takano's prediction.

Observe that a similar structure in English is grammatical:

- (26) They all said that John might have been being followed, and
being followed he might have been. (= (46b) p.116, Huang(1993))

Preposing of a passive sentence is allowed in English. Supposing Takano is correct in the claim that an unbound subject trace triggers the reconstruction, how can we account for the contrast that preposing of passives is ungrammatical in Japanese yet grammatical in English?

We will present an answer to this question in the following section.

3.4 VP-External Subject Analysis & VP-preposing

In the previous sections we saw that Takano's arguments accounts for predicate preposing in English, but not in Japanese. In Takano's argument, an unbound subject trace plays a crucial role in triggering reconstruction. Takano argues that a reconstruction process at LF is triggered to eliminate the unbound trace of a subject contained in a preposed clause, because otherwise the structure would be excluded by the Binding Condition. If we assume that a Japanese preposing structure does not contain an unbound subject trace and that it is crucially a subject trace which triggers reconstruction, the latter naturally will not take place; the preposed constituent will not be put back into its unpreposed position. If reconstruction does not occur, a preposed VP containing an object trace, such as a passive or unaccusative, will be rendered ungrammatical. This is exactly what the VP-external subject structure proposed in chapter 2 predicts. Under the [Spec, PrP] Subject Hypothesis given again in (27), blocking of VP-preposing can be explained.

(27)

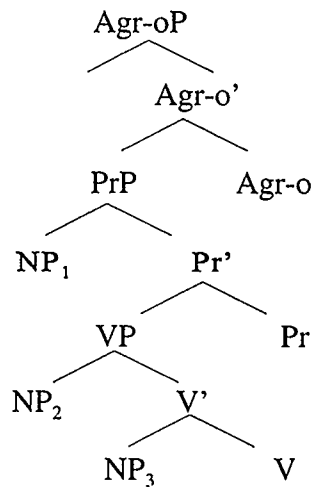

The canonical subject is generated in Spec of PrP, the NP₁ position. Predicate preposing fronts the VP constituent only, excluding the subject. In the case of the passive construction, the internal argument moves from within VP to the NP₁ position, leaving its trace within VP. If the VP is preposed, the VP-internal trace will be unbound. We crucially assume that reconstruction cannot be triggered since the preposed VP does not have an unbound subject trace.

This structure also suggests that the Japanese subject does not raise to Spec of Agr-sP for Case checking overtly. If the subject in the NP₁ position raises overtly, then the subject trace would make reconstruction of the preposed PrP predicate possible. To exclude this possibility, we must conclude that the subject in the NP₁ position will not raise overtly.

The evidence to support the claim that the subject stays *in situ* in Japanese comes from Kitagawa (1986)⁶. He notes that extraction of a Wh-subject out of a Wh-island is possible in Japanese but not in English. (28) is a Japanese example of Wh-extraction out of

⁶ See also Lasnik & Saito (1992), and Saito (1985).

a Wh-Island.

(28) Zemusho -wa [_{CP} dare-ga nani-o katta -ka] shirabe -teiru-no
 revenue office-Top who-NOM what-ACC bought-Q investigate-Prog-Q

'Who is the person x such that the revenue office is investigating what x bought ?'

(=(6) p.224, Kitagawa (1986))

In Japanese, Wh-extraction out of a Wh-Island is grammatical. This Japanese example contrasts with the following English equivalent.

(29)*Who_i is the revenue office investigating [what_j t_i bought t_j]?

Both would have the same LF representation as shown in (30) under the [Spec, IP] Subject Hypothesis.

(30)[_{CP} who_i the revenue office is [_{VP} investigating [_{CP} what_j [[_{IP}t_i[_{VP} bought t_j]]]]]]

Kitagawa argues that the structure is ungrammatical in English because the t_i is not properly governed, since INFL is not a lexical category and cannot head-govern a trace. On the other hand, the grammatical Japanese example indicates that the subject in Japanese is not in Spec of IP, but located in a lexically governed position, which is Spec of VP. His analysis suggests in our terms that the subject in Japanese remains *in situ*, where it is theta-assigned by the V-Pr complex. Therefore, the subject trace due to WH-extraction is theta-governed by the V-Pr complex and the result is grammatical, as the following illustration shows⁷. We assume the

⁷ Irrelevant details are omitted in (31).

verb movement is covert in Japanese, because an overt verb movement to Pr would result in SVO word order⁸.

(31)

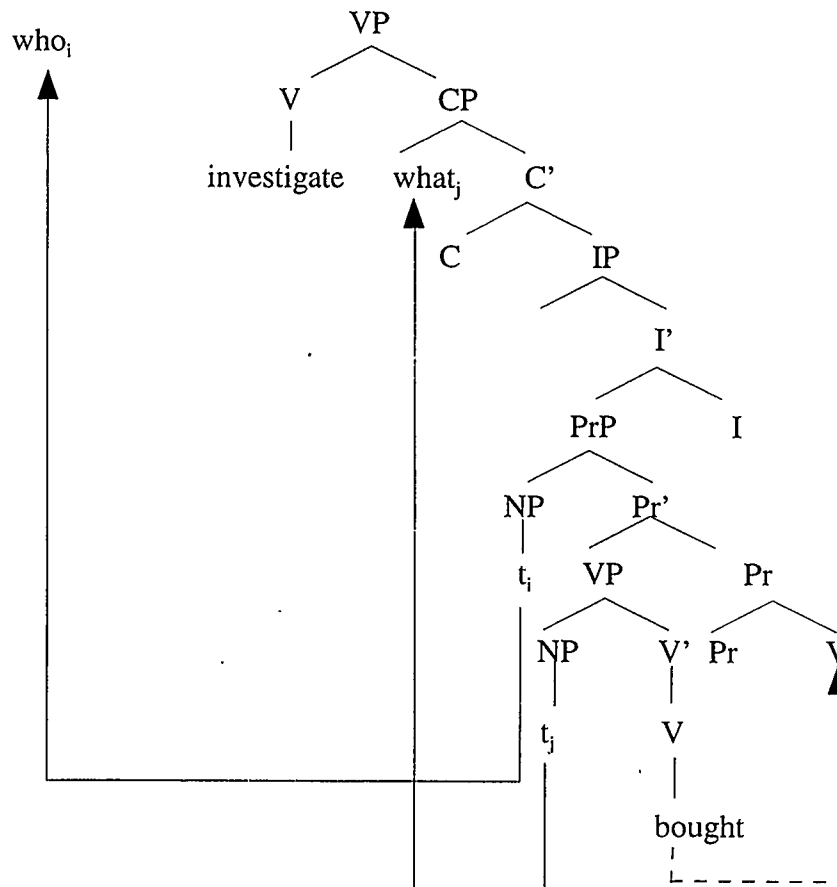

Thus, the grammaticality of extraction of a Wh-subject out of a Wh-island suggests that the subject remains in Spec of PrP until LF in Japanese.

⁸ We follow Nemoto (1993) and Watanabe (1993) in that scrambling of the object constitutes overt movement to Spec of Agr-oP, and that the object remains *in situ* otherwise.

For a unified argument, let us adopt the same VP-external structure for English. Suppose that in English V adjoins to Pr overtly. A subject is generated in Spec of PrP and subsequently raises to Spec of Agr-sP for feature checking before Spell-Out, since the N-features of Tense in a finite clause are strong in English (Marantz 1994). Suppose further that the fronted predicate is PrP. The preposing predicate PrP contains a trace of the raised subject and the VP constituent, and reconstruction is triggered, as Takano suggested. Thus, in an English passive construction, the preposed structure always reconstructs to the unpreposed position, all traces being properly governed by their antecedents. The passive structure in English is shown in (32)..

(32)

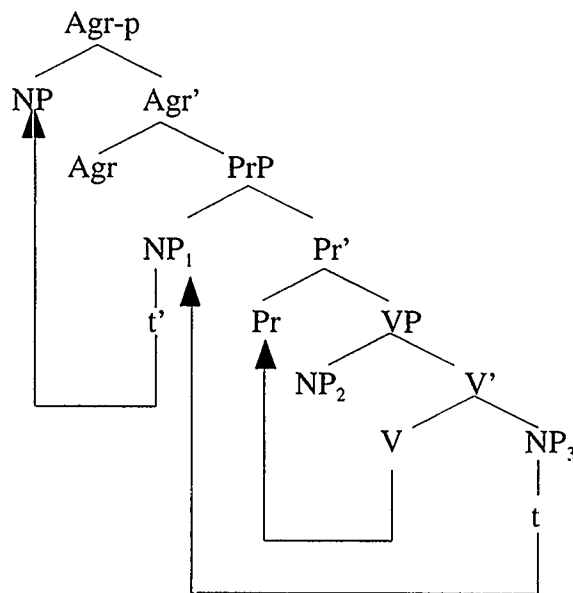

This is also consistent with Kitagawa's analysis. Our framework can predict the ungrammaticality of extraction of a Wh-subject out of a Wh-island in English easily. The illustration in (33) shows Wh-extraction out of a Wh-island in English.

(33)

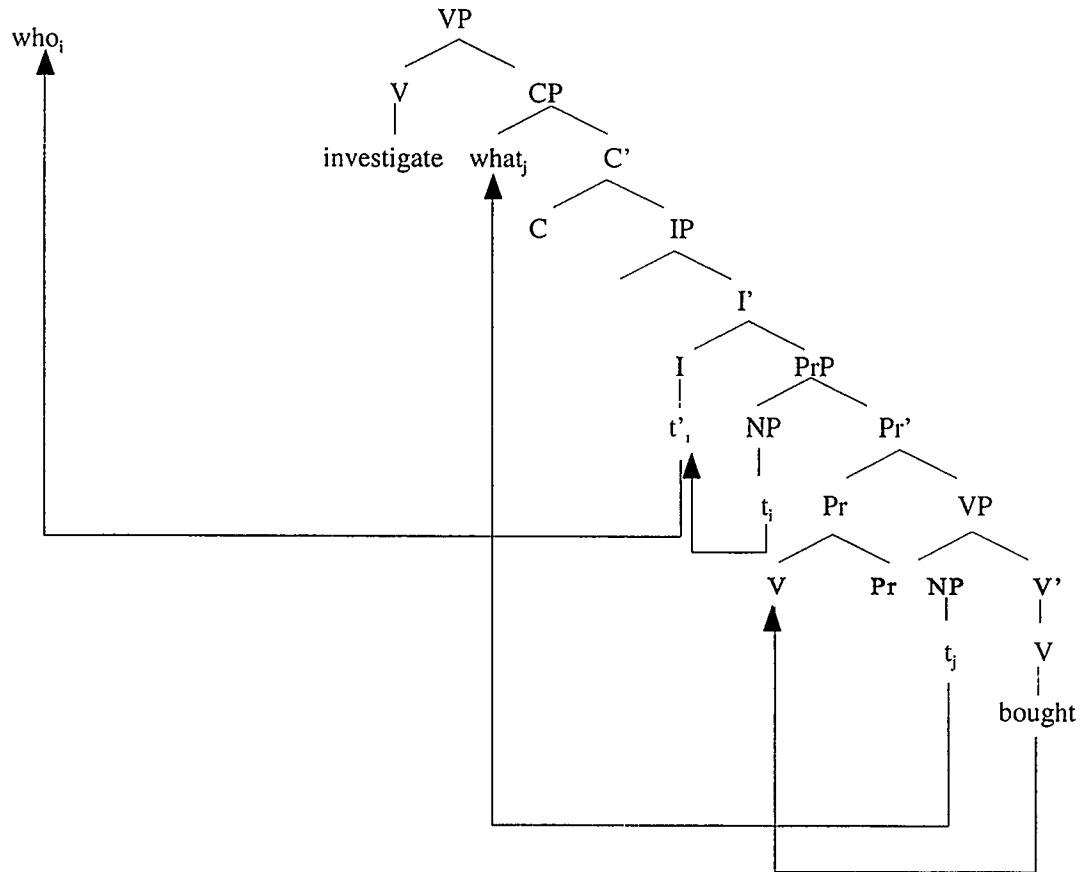

The subject is raised to Spec of T overtly, and the raised subject is no longer within the governing domain of Pr. WH-extraction of the subject out of a WH-Island will leave the trace of the raised subject, t'_i , is outside the governing domain of Pr, and therefore it is not theta-governed by the V-Pr complex. The trace t'_i is not antecedent-governed either; its antecedent *who* is too far away to do so. Thus, Wh-extraction out of a Wh-Island in English is ruled out, and Kitagawa's analysis is consistent with our proposal.

The question that arises is why should English preposed predicates be reconstructed PrP while their Japanese counterparts are unreconstructed VPs. We speculate that the

difference lies in the nature of the inflectional heads in the two languages. In English, Tense has strong N features, so the subject raises overtly while in Japanese Tense has weak N features, so the subject raises covertly. In other words, in English the subject always raises prior to Spell-Out, leaving a trace in Spec of PrP whereas in Japanese, the subject normally raises after Spell-Out, so there is no trace in Spec of PrP at the point where predicate preposing occurs.

Moreover, as we indicated in (31), Japanese V does not undergo an overt movement. If Pr has strong V features in English, but weak V features in Japanese, the verb will raise overtly to Pr in English, but not in Japanese. If predicate preposing involves movement of the constituent headed by the verb, this will entail movement of PrP in English and VP in Japanese.

Thus, the evidence from VP-preposing in Japanese has shown that the subject must be generated outside VP. The asymmetry between English and Japanese on VP-preposing is attributed to two language-specific differences; firstly, English predicate fronting involves preposing of PrP while Japanese predicate fronting involves preposing of VP, assuming the structure in (27), where a subject is generated in Spec of PrP. Secondly the subject trace due to Case checking considerations triggers reconstruction of PrP in English, while there is no such trace in Japanese.

3.5 Summary

In this chapter we have discussed previous accounts of VP-preposing, and defined the syntactic operation of VP-preposing. We discussed Takano's analysis of VP-preposing under the [Spec, VP] Subject Hypothesis, and introduced Japanese evidence on VP-preposing, which is counter to his analysis. Based on the Japanese evidence, we presented

an alternative analysis of predicate preposing involving PrP, claiming that PrP undergoes preposing in English while VP preposes in Japanese. Thus, we demonstrated that the analysis of VP-preposing lends strong support to our [Spec, PrP] Subject Hypothesis.

CHAPTER 4

STATIVE VERBS

4.1 Introduction

In chapter 2 we proposed that Pr projects event structure onto syntax. In transitives and unergatives, the instigator of an event is base-generated in Spec of PrP, indicating the beginning point of the event. In unaccusatives, because the verb is eventive, PrP is projected, but Spec of PrP is empty, since the only argument of an unaccusative verb denotes the end point of the event and occupies the verb's complement position. We assumed that Pr is inert when its Spec position is not filled. We also suggested that stative structures do not have PrP, as they do not constitute an event; and consequently, the subject of a stative verb is generated in Spec of VP.

In this chapter we present evidence to support our proposal about the stative structure. Specifically we provide evidence from VP-preposing to show that the subject of stative verbs is in Spec of VP, rather than Spec of PrP. We also discuss the alternation in Case assignment to the object of stative verbs and nonstative verbs, and attempt to account for Nominative Case marking of the object. We speculate that Pr is responsible for Accusative Case checking, and that the object of stative verbs is unable to receive Accusative Case because PrP is not present in this context.

4.2 Stative Verbs and the Subject in Japanese

presents a detailed analysis of stative verbs, which include three categories: competence, nonintentional perception, and possession. The following are some examples from each category:

(1) Competence

a. John-ni Eigo -ga dekiru.

John-to English-NOM capable to do

'John can speak English.'

(=(27b) p.338, Kuno (1976))

b. John-ni kami-ga kireru.

John-to paper-NOM capable to cut

'John can cut a piece of paper'

(2) Nonintentional Perception

a. John-ni yama -ga mieru.

John-to mountain-NOM see

'John sees mountains.'

b. Taro-ni eigo -ga wakaru

Taro-to English-NOM understand

'Taro understands English.'

(=(5f) p.46, Kubo (1992))

(3) Possession

a. John-ni kane-ga aru

John-to money-NOM have.

'John has money.'

b. Taro-ni kane-ga iru.

Taro-to money-NOM need

'Taro needs money.'

(=(5c) p.45, Kubo (1992))

In Japanese, transitive stative verbs generally mark one NP with the morpheme and the other NP with the Nominative Case marker *ga* (Kuno 1973). This is illustrated by (95), wherein the second NP bears the Accusative Case marker *o* ungrammatically.

(4)a. *Tom-ni eigo -o dekiru.

Tom-to English-ACC capable to do

'Tom can speak English.'

b. *John-ni yama -o mieru.

John-to mountain-ACC see

'John sees mountains.'

c. *Taro-ni kane -o iru.

Taro-to money-ACC need

'Taro needs money.'

In the nonstative structure, the Nominative marked NP is a subject of a sentence, but this is not the case in the stative structure. The Nominative Case marked NP is not a logical subject of the sentence. As briefly mentioned in chapter 1, Japanese has an honorification process, which is triggered when the subject or object is worthy of respect¹. The

1

See Harada (1976) for an detailed analysis of Japanese honorifics.

discontinuous morpheme *o...ninar* attaches to the predicate of a sentence when its subject is a respected person.

(5)a. Sensei-ga o -ide -ninaru.

teacher-NOM Hon-come-Hon

'The teacher(hon) comes(hon).'

b.*Kodomo-ga sensei -ni o -ai -ninaru.

child -NOM teacher-DAT Hon-meet-Hon

'A child (hon) meets(hon) the teacher.'

In (5a) the subject is a 'teacher', and the honorific morpheme grammatically attaches to the verb, whereas in (5b) the subject is a 'child', and the subject honorification should not have taken place. The contrast in (5) shows that the subject must be someone who can be respected to receive the subject honorification on the verb. This process has been used as a test for the subjecthood of noun phrases. In the following examples, 'teacher' is a respected person, and should trigger subject honorification.

(6)a. Sensei -ni sono gakusei-ga o -wakari -ninaru.

teacher-to that student-NOM Hon-understand-Hon.

'The teacher(hon) understands(hon) that student.'

b.*Kare-ni sensei-ga o -wakari -ninaru.

he -to teacher-NOM Hon-understand-Hon

'He understands(hon) the teacher(hon).'

In this subsection we provide evidence from VP-preposing to support the stative structure.

As discussed in 3.3, VP-preposing is generally allowed in Japanese with some exceptions, which include passives and the scrambled structures. The stative structure also blocks VP-preposing (Kubo 1992). Some of the examples given in (1-3) are repeated in (8) below with their VP-preposed structures in (9).

(8)a. Tom-ni eigo -ga dekiru.

Tom-to English-NOM capable to do

'Tom is capable of English.'

b. John-ni yama -ga mieru.

John-to mountain-NOM see

'John sees mountains.'

c. John-ni kane -ga aru

John-to money-NOM have.

'John has money.'

(9)a.*[Eigo-ga deki-wa]_i Tom-ni t_i suru.

b.*[Yama-ga mie-wa]_i John-ni t_i suru.

c.*[Kane-ga ari-wa]_i John-ni t_i suru.

VP-preposing with a stative verb results in an ungrammatical sentence.

Kubo demonstrates the contrast between nonstative and stative verbs in its sharpest form with the verb *wakaru* 'understand'. Stative verbs generally take a Nominative object, but the verb *wakaru* 'understand' can take either an Accusative object or a Nominative object.

- (10)a. Hanako-ga kodomo-no kimochi-o waku
 Hanako-NOM child -GEN feeling -ACC understand
 'Hanako understands children's feeling.'
- b. Hanako-ni kodomo-no kimochi-ga waku
 Hanako-to child -GEN feeling -NOM understand

(=(11a) p. 56, Kubo (1992))

Kubo (1992) notes that the Accusative Case marking alters the interpretation of the verb *waku*; an Accusative object is associated with an activity interpretation, while a Nominative object is associated with a stative interpretation. (11) is a piece of evidence presented by Kubo to show the alternation of interpretation.

- (11) Kodomo-no kimochi-o/*ga waku -e
 child -GEN feeling -ACC/*NOM understand-imperative
 'Understand children's feelings!'

(=(15) p. 53, Kubo(1992))

(11) shows that the Nominative object is not compatible with the imperative mood. Given that imperatives are only possible with nonstative verbs in Japanese (Kuno 1973), the contrast in (11) suggests that the stative *waku* 'understand' marks its object with Nominative Case, while the nonstative *waku* marks its object with Accusative Case. VP-preposing occurs only when *waku* is nonstative.

- (12)a. John-ga kodomo-no kimochi-o waku
 John-NOM child -GEN feeling -ACC understand
 'John understands children's feeling.'

b. [Kodomo-no kimochi-o wakar-wa]; John-ga t_i shita.

(=(12a) P.50, Kubo (1992))

(13)a. John-ni kodomo-no kimochi-ga wakatta

John-to child -GEN feeling -NOM understand

b.*[Kodomo-no kimochi-ga wakari-wa]; John-ni t_i shita

(=(12b) p.51, Kubo 1992))

(12) has a nonstative interpretation with a Nominative subject and an Accusative object and (13) has a stative interpretation with a *ni* marked subject and a Nominative object. Preposing is possible only with nonstative *wakaru* in (12). Stative *wakaru* does not permit VP-preposing. The contrast in VP-preposing between nonstative and stative verbs, that is, nonstative verbs allow VP-preposing while stative verbs do not, follows directly from the structures in (7). With nonstative verbs, VP-preposing does not cause any ill-formedness because the subject is in Spec of PrP. VP movement does not violate any constraints. With stative verbs, which have a subject in Spec of VP, VP-preposing is ungrammatical. To derive the preposed sentence, V' must be raised, violating constraints on movement, which we discussed in section 3.4. Thus the asymmetry in VP-preposing between nonstative and stative verbs supports the structures in (7).

4.4 Accusative Case and Pr

As in many languages, objects of stative verbs are assigned Nominative Case rather than Accusative Case. In Japanese such objects bear the Nominative marker *-ga* rather than the Accusative marker *-o*. In this section we will attempt to account for the alternation between *ga* and *o* within the Case checking theory. Specifically we propose that the

functional node Pr, not V, is responsible for Accusative Case, at least in Japanese; Pr is a Case-bearing head, and the Agr-Pr complex checks Accusative Case feature against an NP in Spec of Agr-o. In the stative structure, where Pr is not projected, Accusative Case checking is not possible and the object NP checks its Case against Agr-oP.

4.4.1 Case Marking of the Object and Stativity

In section 4.1 we saw that stative verbs in Japanese generally mark the subject with the morpheme *ni* and the object with Nominative Case marker *ga*. When the object bears the Accusative Case marker *o*, the sentences become ungrammatical. However, there is one exception to this generalization. The verb *wakaru* 'understand' can take both Accusative Case and Nominative Case, as we also saw in 4.1. When the object bears Accusative Case, the subject must take Nominative Case. Kubo (1992) notes that the Accusative Case marking alters the interpretation of the verb *wakaru*; an Accusative object is associated with an activity interpretation, while a Nominative object is associated with a stative interpretation. (14) is a piece of evidence presented by Kubo to show the alternation of interpretation.

- (14) Kodomo-no kimochoi-o/*ga wakaru -e
 child -GEN feeling-ACC/*NOM understand-imperative
 'Understand children's feeling.'

(=(15) p. 53, Kubo(1992))

(14) shows that the Nominative Case object is not compatible with the imperative mood. Given that imperatives are only possible with nonstative verbs in Japanese (Kuno 1973), the contrast in (14) suggests that the stative *wakaru* 'understand' marks its object with Nominative Case, while the nonstative *wakaru* marks its object with Accusative Case.

Similarly, other stative verbs cannot be put in imperative.

Additional evidence that object Case marking is sensitive to the stativity of the verb comes from causative structures. In Japanese, causativization requires a causative morpheme *sase* to attach to a base verb to create a complex verb meaning 'make/let + V'. The subject of the base verb (i.e. the causee) is marked by Dative Case when the base verb is transitive.

(15)a. Tom-ga piza -o taberu.

Tom-NOM pizza-ACC eat

'Tom eats pizza.'

b. John-ga Tom-ni piza-o tabe-sase -ru.

John-NOM Tom-DAT pizza-ACC eat -Cause-present

'John makes Tom eat pizza.'

The causative morpheme *sase* is very productive, but it does not attach to stative verbs. In Japanese, as in many languages, stative verbs do not undergo causativization.

(16)a. John-ni yama -ga mieru.

John-to mountain-NOM see

'John sees mountains.'

b.*Tom-ga John-ni yama -ga mier-ase -ru.

Tom-NOM John-DATE mountain-NOM see -Cause-Present

'Tom makes John see mountains.'

(17)a. Hanako-ni kodomo-no kimochi-ga wakaru

Hanako-to child -GEN feeling -NOM understand

'Hanako understands children's feeling.'

- b.*Tom-ga Hanako-ni kodomo-no kimochi-ga wakar -ase -ru
 Tom-NOM Hanako-DAT child -GEN feeling -NOM understand-Cause -present
 'Tom makes Hanako understand children's feelings.'

When the object NP in *wakaru* bears Accusative Case, however, the causative structure becomes possible.

- (18) Tom-ga Hanako-ni kodomo-no kimochi-o wakar -ase -ru
 Tom-NOM Hanako-DAT child -GEN feeling -ACC understand -Cause -pres
 'Tom makes Hanako understand children's feeling.'

Given the fact that only nonstative verbs can be causativized, the grammaticality of (18) further indicates that *wakaru* with an Accusative object is nonstative. The contrast between (17) and (18) again suggests that object Case marking is sensitive to the aspectual classification of the verb; stative verbs select a Nominative Case marked object while nonstative verbs select an Accusative Case marked object.

4.4.2 Case Marking of the Subject and Stativity

The subjects of stative verbs so far discussed are marked with the morpheme *ni*. Japanese stative verbs alternatively allow the subject to bear a Nominative Case marker *ga*, as shown below:

- (19) Tom-ga eigo -ga dekiru.
 Tom-NOM English-NOM capable to do
 'It is Tom who is capable of English.'

However, when the subject is marked with *ga*, the interpretation changes from neutral description to exhaustive listing, as briefly mentioned in 2.6.3. In Japanese, there are two distinct interpretations associated with the Nominative Case marker *ga*, namely *ga* of neutral description and *ga* of exhaustive listing, as shown in (20) (Kuroda 1965 and Kuno 1973).

(20) John-ga kita

John-Nom came

i) Neutral description: 'John came.'

ii) Exhaustive listing: 'It is John who came.' (= (23a) p.51, Takano (1986))

When the predicate represents a state, *ga* is only associated with an exhaustive-listing interpretation (Kuroda 1965 and Takano 1986).

(21) John-ga gakusei-da

John-NOM student-is

'It is John who is a student.'

'*John is student.' (= (23b) p.51, Takano (1986))

(22(=19)) Tom-ga eigo -ga dekiru.

Tom-NOM English-NOM capable to do

'It is Tom who is capable of English.'

'*Tom is capable of English.'

When the subject bears *ni*, the interpretation changes to a neutral description.

(23(=1))Tom-ni eigo -ga dekiru.

Tom-to English-NOM capable to do

'Tom is capable of English.'

'*It is Tom who is capable of English.'

Kubo (1992) argues that the subject with exhaustive-listing interpretation is projected in a higher position than the subject with neutral description. If Kubo is right, the Nominative subject with an exhaustive listing interpretation occupies a different position from the one with an neutral interpretation. Even if Kubo's analysis turns out to be wrong, we assume that the semantic difference must be reflected in the syntactic structure, and that the subject with an exhaustive listing interpretation should require an independent analysis. We will not investigate the syntactic structure of exhaustive listing further, limiting our analysis to the structure of neutral description. It suffices to note that the interpretation of neutral description is attained when the subject is associated with *ni*, not with the Nominative marker *ga*.

4.4.3 Postposition *ni*

Classification of the morpheme *ni* in the stative construction is rather controversial because Japanese has several homophonous particles *ni*, including a Dative Case marker and a postposition like the English *to* or the French *à*. Miyagawa (1989) demonstrates that quantifiers can modify Case-marked NPs, but cannot modify PPs, as shown in (24) and (25).

(24) Case marked NPs

a. [Gakusei-ga 3-nin] piza -o tabeta.

students-NOM 3-CL pizza-ACC ate

'Three students ate pizza.'

b. John-ga [piza -o 2-kire] tabeta

John-NOM pizza-ACC 2-CL ate

'John ate two slices of pizza.'

(=(6) p.8, Sadakane and Koizumi (1995))

(25) Postpositions

a.*John-ga [gakusei-kara 3-nin] purezento-o moratta.

John-NOM students-from 3-CL presents -ACC received

'John received presents from three students.'

b.*Mary-ga [konputaa-de 2-dai] ronbun-o kaita

Mary-NOM computer-by 2-CL paper -ACC wrote

'Mary wrote a paper with two computers.'

(=(7) p.8, Sadakane and Koizumi (1995))

The contrast between (24) and (25) shows that modification of the subject and object NPs with a numeral quantifier is allowed, while modification of PPs is not.

Terada (1989) argues that the numeral quantifier is a functional head which selects an NP as its complement, as illustrated in (26)².

² Shlonsky (1991) proposes a similar structure for Modern Hebrew.

(26)

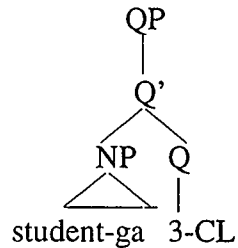

The constituent form 'student-ga 3-CL' is a QP, which is headed by the numeral quantifier Q^3 . As shown in (24) and (25), Q subcategorizes for an NP, not for a PP. Modifying Terada's proposal slightly we assume that Q selects NP, which bears the features [+N, -V], and that it cannot select PP, which has the features [-N, -V]⁴.

³ We follow Shlonsky's assumption that a functional head Q can transmit Case to an NP which it governs.

4

If Case is the head of a functional category KP, as Travis and Lamontagne (1992) propose, the structure in (26) would look like that shown below.

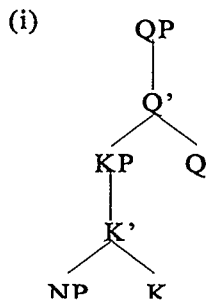

Here KP is the outmost layer of the nominal system. Following Cowper (1987), then we assume that K is not specified for the features [+/-N, +/-V] so that the features of N percolate up to the KP node, which satisfies the QP requirement for its complement.

(27)

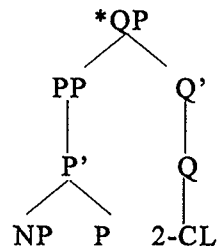

The contrast between (24) and (25) provides us with a diagnostic to determine whether the morpheme *ni* in the stative construction is a postposition or a Case marker. If we modify the subject phrase with a quantifier and the result is grammatical, we can assume that *ni* is a Case marker. If the result is ungrammatical *ni* is a postposition.

(28)a.*[Gakusei-ni 3-nin] eigo -ga dekiru.

students-to 3-CL English-NOM capable to do

'Three students are capable of English.'

b.*[Gakusei-ni 3-nin] yama-ga mieru.

students-to 3-CL mountain-NOM see

'Three students see mountains.'

(28) shows that *ni* in the stative structure may not be associated with numeral quantifiers; thus it must be a postposition, not a Case marker (see Sadakane and Koizumi (1995)).

4.4.4 Pr as Accusative Case-Bearing Head

We have suggested that in the stative construction, the subject, which is generated

in Spec of VP, is associated with a postposition, while the object bears Nominative Case. In nonstative clauses, the subject and object NPs bear Nominative Case and Accusative Case, respectively. To account for the contrast in Case marking, we would like to propose a minimal modification to the Case checking theory, arguing that the functional category Pr, not V, is the Accusative Case-bearing head.

In Chomsky (1992), as summarized in 1.2, Nominative Case and Accusative Case are associated with T and V respectively. These Case features are checked in conjunction with Agr against NP in Spec of AgrP. T raises to Agr-s, and checks its Nominative Case feature against an NP in spec of Agr-sP. Similarly, V raises to Agr-o and checks off its Accusative Case feature against an NP in Spec of Agr-oP. Thus, T determines Nominative Case, and V determines Accusative Case. The modification to the Case theory which we propose is that the functional node Pr, not V, is responsible for Accusative Case, at least in Japanese. (29) illustrates the movement for Accusative Case checking: V adjoins to Pr to assign a theta role, then the V-Pr complex adjoins to Agr-o to check off its Accusative Case features against NP in Spec of Agr-oP.

(29)

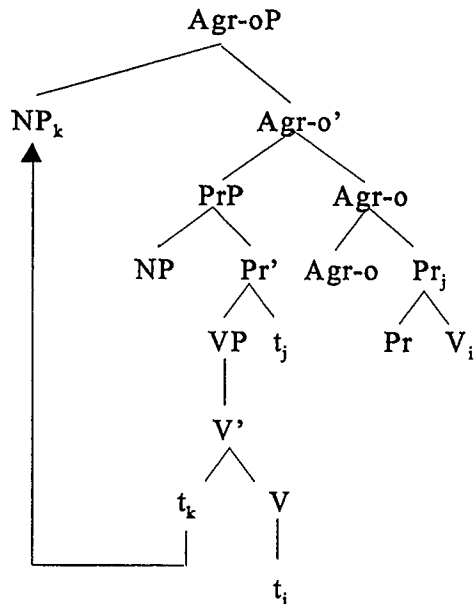

The functional category Pr, not V, is an Accusative Case-bearing head and it discharges the Case feature in the Pr-Agro complex, not in the V-Agro complex. We further suggest that the object of a stative verb, which is lacking Pr, is unable to have its Accusative Case checked because PrP is not projected, thus triggering Nominative marking on the object. Without Pr, the object which raises to Spec of Agr-oP cannot have its Case features checked off. In order to save the structure, it raises further to Spec of Agr-sP for Case checking. In the Case checking theory of Chomsky (1992), Case features for NP are not specified for Nominative or Accusative; Case is determined depending on which Agr head NP is involved. If checking takes place in Spec of Agr-sP, then the NP bears Nominative Case; and if checking takes place in Spec of Agr-oP, then the NP bears Accusative Case. In the stative verb construction, the object NP cannot check its Case feature at Spec of Agr-oP because the Accusative Case bearing head Pr is not present, and has to raise further to the next available

position for Case checking. Thus, the object in the stative verb construction bears Nominative Case. This object movement, however, leaves no Agr for the subject NP to check off its Case features against. Thus, PP is projected to assign Case to the subject NP to save the derivation. We will show one piece of evidence to support movement of the object NP in the next subsection.

4.4.5 Scope of Negation

One piece of evidence supporting movement of the object NP to Spec of Agr-sP comes from facts about the scope relation of sentential negation to quantifiers. Under the split INFL hypothesis, negation is located between T and Agr-o. In a nonstative sentence, the subject is in Spec of Agr-sP at LF, and should have scope over the sentential negation. The object, on the other hand, is in Spec of Agr-oP, and should not have such scope. The asymmetry between objects and subjects with respect to negation in Japanese is shown below:

(30)a. Gakusei-ga [subeteno piza -o] tabe-nai.

students-NOM all pizza-ACC eat -Neg

(i) 'Students do not eat any pizza.'

(ii) 'Students do not eat all the pizza.'

b. Subeteno gakusei-ga piza -o tabe-nai

all student-NOM pizza-ACC eat -Neg

'None of the students eats pizza.'

(30a) gives an ambiguous interpretation, which we assume is due to optional quantifier raising to Spec of CP. In interpretation (i), the quantifier 'all', which modifies the object NP,

raises to Spec of CP and has scope over the negation at LF. When the quantifier stays *in situ*, the negation has scope over the quantifier 'all', yielding interpretation (ii). In (30b), the subject NP has scope over the negation. Quantifier raising does not alter the relative positions of the quantifier and the negation; the quantifier is higher than the negation whether the quantifier undergoes raising to Spec of CP or stays in Spec of Agr-sP with the subject NP.

Now let us consider negated stative sentences containing a quantifiers.

- (31)a. Gakusei-ni subeteno kotae -ga wakara -nai.
 students-to all solutions-NOM understand-Neg
 'Students cannot answer any of the questions.'
- b. Subeteno gakusei-ni kotae -ga wakara -nai
 all student -to solution-NOM understand-Neg
 'None of the students can answer the question.'

The interpretations in (31) are not ambiguous; the subject and object NP in the stative both have scope over the negation. The interpretation is in a sharp contrast to (30), where only the subject NP, not the object NP, has scope over the negation. This fact indicates that the object NP of a stative verb behaves in the same way as the subject NP of a nonstative verb with respect to negation. If we assume that the object in the stative structure, like the subject NP in the nonstative structure, raises over the negation to Spec of Agr-sP, this similarity can be accounted for⁵. Moving to Spec of Agr-sP for Case checking, the object NP ends up in a higher position than the negation, obtaining wide scope over it. Thus, the scope relation of

5

Harley (1995) reaches a different conclusion for Icelandic nominative objects. Her analysis using negative polarity items indicates that the nominative object in Icelandic raises to Spec of Agr-oP, but not over the sentential negation to Spec of TP or Spec of Agr-oP. I leave open the issue of accounting for the contrast.

negation is consistent with the hypothesis that the object NP must raise to Spec of Agr-sP at LF, and lends support to our claim that the object of a stative verb checks its Case in Spec of Agr-sP, not Spec of Agr-oP.

4.4.6 Further Issues

The scope relation between negation and quantifier shows that the object NP moves to a position above negation. However, there seems to be no other evidence to support the movement of the object NP, although there is no evidence counter to our claim. Takezawa (1987), cited in Harley (1991), gives analyses of stative verbs, among which he provides two pieces of evidence, namely the Weak Crossover effect and quantifier floating, to show the structural relationship of the subject and the object. These tests all confirm that the *ni* marked subject is structurally higher than the object at D-structure or at LF, but neither support nor contradict our arguments on the object movement. We attempted to demonstrate movement of the object by using the scopal relation between some adverbial phrases and the object, but failed to obtain a clear result. The native speakers we consulted did not give clear judgements, and we could not find related analyses in the literature either.

Another remaining issue is how the subject NP is marked by a postposition. Throughout chapter 4, we have argued that Pr is an Accusative Case-bearing head, and that the object NP in the stative construction, which has no PrP, is unable to check its Accusative Case features off in Spec of Agr-oP and proceeds to the second available place, Spec of Agr-sP, to satisfy its Case requirement. This movement of the object NP deprives the subject NP of a Case checking place, and forces the subject NP to appear as a PP as a last resort. We admit that this 'last resort' argument is speculative. In the literature, many languages are reported to have an Experience subject which appears as a Dative subject or a PP. In this respect, the Japanese *ni* marked subject is not exceptional. There must be an explanation for

the fact that the subject of stative and psych verbs generally bears Dative marking, other than 'the last resort' mechanism. This topic also awaits future research.

4.5 Summary

To sum up this chapter, we have proposed that the functional projection Pr is not generated in the stative structure, and that the subjects of stative verbs are generated in Spec of VP. This structure is motivated in section 2.6.4 on the basis of the event structure analysis of van Voorst (1988), and independently supported by the facts of VP-preposing seen in this chapter. The Nominative Case marking on objects is accounted for by introducing a modification to the feature checking theory; Pr, not V, is an Accusative Case-bearing head. The stative structure, which has no Pr, does not have an Accusative Case checking mechanism, so that the object NP raises to Spec of Agr-sP for the Nominative Case. This object NP movement is supported by the scope relation between such objects and sentential negation. We speculate that the subject NP appears as a PP as a last resort, because the object NP has raised to Spec of Agr-sP, preventing the subject NP from checking its Case.

CHAPTER 5

CAUSATIVES

We have argued that Pr is a syntactic head responsible for projecting event structure in syntax in part because it makes possible the introduction of an object of initiation or actualization as a subject. In chapter 2, we proposed an extra spec position, Spec of XP, below Agr-oP but above VP, and in chapter 3 we provided additional evidence that the subject is in Spec of XP rather than Spec of VP. In chapter 4 we have shown that this XP contributes aspectual and thematic information related to the subject. An XP of this type has been independently proposed by a number of linguists, and we are calling this projection PrP, following Bowers.

In this chapter, we provide additional support for our claims based on the analysis of causative constructions. We have already established that in active sentences the head of PrP is filled by an abstract element and that only arguments which are construed as event instigators may occupy Spec of PrP. In this chapter we will show that Pr in the causative construction is filled by an overt causative morpheme, and that the causer, which is clearly an event instigator, is inserted in Spec of PrP.

It has also been suggested that causativized events have two subcomponents, the cause and the consequent or core event. We will argue that causativized events with this bipartite structure have an added PrP containing the added causer. This analysis of causatives provides further support for our claims that PrP is a functional projection whose semantic contribution consists of aspectual and thematic information pertaining to the subject argument.

Specifically, we will discuss the structure of the Japanese causative and examine the

proposal will resolve some of the controversial issues related to the causative, and provides additional motivation for the view that Pr introduces an initiator subject in Japanese.

In 5.1 we summarize the facts of the Japanese causative construction. The discussion will be focused on two controversial issues of the causative structure: monoclausal versus biclausal underlying structures, and lexical versus analytical causatives. In 5.2 we discuss Miyagawa (1989)'s analysis of the Japanese causative. In 5.3 we apply our framework to the Japanese causative, assuming a structure consistent with Miyagawa's analysis, and explore the interplay between the projection of stem verbs and the causative Pr projection. We also demonstrate that the causative Pr projection selects Agr-oP as its complement. In 5.4 we provide an account of the reflexive binding facts consistent with our analysis. Finally in 5.5, we summarize the results of this chapter.

5.1 Brief Summary of Japanese Causatives¹

5.1.1 A Monoclausal or Biclausal Derivation ?

The causative in Japanese is formed by attaching a bound morpheme (*s*)*ase* to a verb, as shown below.

1

The Japanese causative construction has inductive and permissive readings, and this semantic difference has prompted some linguists to assume distinct structures for the two interpretations. In this paper we limit our discussion to the inductive reading only in order to avoid this complication. See Shibatani (1973, 1976) and Terada (1990) for more discussion.

- (1)a. Hanako-ga arui-ta
 Hanako -NOM walk-Past
 'Hanako walked.'
- b. Taroo-ga Hanako-o aruk-ase -ta
 Taro -NOM Hanako-ACC walk-Cause-Past
 'Taroo caused Hanako to walk.'

The causative construction has been one of the most controversial issues in Japanese linguistics. One problem concerns formation of the causative; there is no consensus among linguists as to whether the underlying structure is simplex or complex. Shibatani (1976) argues that analytical causatives are formed syntactically from biclausal underlying structures (see also Kuroda 1965, Kuno 1973, Terada 1990 for similar arguments)². The main evidence comes from data concerning reflexive binding. It is well-known that the Japanese reflexive pronoun *jibun* 'self' takes a subject NP as its antecedent. In a sentence like the following, the reflexive pronoun unambiguously refers to the subject, Taroo:

- (2) Taroo-ga_i Hanako-o_j jibun-no_{i/*j} heya-de kusugutta.
 Taroo-NOM Hanako-ACC self-GEN room-in tickled
 'Taroo_i tickled Hanako_j in self_{i/*j}'s room.'

If a sentence is derived from a complex structure with two subjects, an ambiguity arises as to which subject the reflexive pronoun refers to. (3) has two subjects, one in the matrix clause and the other in the embedded clause, and the sentence is ambiguous:

² We use "analytical causatives" here to refer to the causative construction which has the clear interpretation of "cause X to do something". See 5.1.2 for further discussion.

- (3) Taroo-ga_i Hanako -ni kagami-ni ututta jibun-o_{i/j} miru-yoo-ni itta.
 Taroo-NOM Hanako-DAT mirror -i reflected self -ACC look told
 'Taroo_i told Hanako_j PRO_j to look at self_{i/j} reflected in the mirror.'

Reflexive binding in the analytical causative construction displays biclausal characteristics, as shown below:

- (4) Taroo-ga_i Hanako-o_j jibun-no_{i/j} heya-de aruk -ase -ta
 Taroo-NOM Hanako-ACC self-GEN room-in walk-Cause-Past
 'Taroo_i caused Hanako_j in self_{i/j}'s room to walk.'

The matrix subject and the causee can both bind a reflexive phrase, and this ambiguity provides strong motivation for positing a biclausal structure.

Other linguists argue for lexical formation of the causative (Farmer 1984, Miyagawa 1989, Uda 1992 among others). According to Uda, one piece of evidence comes from the Do-support structure. Japanese has an emphatic structure similar to Do-support in English. (5) is a canonical sentence and (6) is the Do-support version of this sentence. The topic marker *wa* or any of the contrastive markers such as *mo* 'also' attach to the end of a VP headed by a bare V, and an independent auxiliary *suru* 'do' supports this bare VP.

- (5) John-wa [sushi-o tabe]-ta.
 John-TOP sushi-ACC eat-Past
 'John ate sushi.'

- (6) John-wa [sushi-o tabe]-mo-shi-ta.
 John-TOP sushi-ACC eat -also-do-Past

'John also ate sushi.'

Uda observes that neither emphatic markers like *mo* or the supportive *suru* 'do' can attach inside a causative verb complex. However, they can attach inside a verb compound. For example, *tabete-ki-ta* the verb compound shown in (7) consists of *tabete* a gerundive form of 'eat' followed by *ki* 'come'. (7a) is the canonical sentence. As (7b) and (7c) show, *mo* and *suru* occur at the end of VP as well as between *tabete* and *ki*.

(7)a. John-wa [sushi-o tabete-ki] -ta.

John-TOP sushi-ACC eat -come-Past

'John ate sushi and came.'

b. John-wa [sushi-o tabete-ki] -mo -shi-ta.

John-TOP sushi-ACC eat -come-also-do-Past

'John also ate sushi and came.'

c. John-wa [sushi-o tabe]-mo -shite-ki -ta.

John-TOP sushi-ACC eat -also -do -come-Past

'John also ate sushi and came.'

(7c) contrasts with (8c), where a causative verb becomes ungrammatical if Do-support precedes the causative morpheme.

(8)a. Syota-ga hana -o sak -ase -ta.

Syota-NOM flower-ACC bloom-Cause-past

'Syota made the flowers bloom.'

b. Syota-ga hana -o [sak -ase] -mo -shi-ta.

Syota-NOM flower-ACC bloom-Cause-also-do-Past

'Syota also made the flowers bloom.'

c.*Syota-ga hana-o [saki] -mo s -ase -ta.

Syota-NOM flower-ACC bloom-also-do-Cause-Past

'Syota also made the flowers bloom.' (=52) p.276 Uda (1992))

The emphatic marker and the supportive 'do' may occur after *sakase* 'bloom+Cause', but not inside it. According to Uda, this is because the verb and causative morpheme constitutes a single word in the syntax with no internal constituent boundary at which the emphatic marker may attach.

Thus, the reflexive binding and 'Do-support' data provide conflicting evidence, showing that the Japanese causatives have characteristics of both simplex and complex underlying structures. As a result, analyses of the Japanese analytical causatives range from lexical analyses assuming monoclausal structure to syntactic analyses, in which the causative verb in the main clause takes a clausal complement.

5.1.2 Lexical vs analytical causatives

Another problem with the Japanese causative is that the causative morpheme *sase* has two distinctive interpretations. The following two sentences have the same causative morpheme attached to the verb stem, but the interpretations associated with the morpheme are different.

(9) Taro-ga hana -o sak -ase -ru.

Taro-NOM flower-ACC bloom-Cause-Present

'Taro blooms the flower.'

- (10) Taroo-ga Hanako-o aruk-ase -ta
 Taro -NOM Hanako-ACC walk-Cause-Past
 'Taroo caused Hanako to walk.'

In (9) the causativized verb *sak-ase* 'bloom+cause' behaves simply as a transitive verb, while in (10) *aruk-ase* 'walk+cause' produces an analytical causative interpretation, as the English translations indicate. Miyagawa (1989) calls the first a lexical causative, and the second an analytical causative. The lexical causatives generally have an idiomatic and unanalysable meaning, while the analytical causatives always have a compositional meaning. Linguists who argue for the syntactic formation of a causative from the biclausal underlying structure treat the lexical causative separately, considering the morpheme of the lexical causative a derivational morpheme which is attached to the verb in the lexicon.

5.2 Morphological Analysis of Causatives

Miyagawa (1989) points out that the monoclausal versus biclausal distinction between the lexical and analytical causatives discussed in the previous subsection misses a generalization, given the fact that they both have the same morpheme, and develops a unified analysis based on this morphological identity.

According to his account, there are two classes of causative verbs, blocked and unblocked, depending on whether or not intransitive verbs have a transitive counterpart in the lexicon. In the blocked causative group, where the intransitive verb has a transitive counterpart, affixation of a causative morpheme *sase* in the lexicon is blocked, and the lexical transitive verb is assigned the causative interpretation. However, affixation of a causative morpheme may occur post-lexically, yielding an analytical causative interpretation. In the unblocked causative group, which does not have a lexical transitive counterpart,

affixation of the causative morpheme in the lexicon is not blocked, yielding a lexical causative interpretation. We will examine Miyagawa's proposal in detail in the remainder of this section, as we rely heavily on his analysis for our argument.

5.2.1 Blocked causatives

Examples of blocked causative verbs with semantically related intransitive and transitive pairs, originally due to Zenno(1985), cited in Miyagawa (1989), are shown in (11).

(11) Intrans. Stem	Trans. Stem	Causative
agar 'rise'	age 'raise'	agar-sase 'cause to rise'
de 'come out'	das 'put out'	de-sase 'cause to come out'
hair 'come in'	ire 'put into'	hair-sase 'cause to come in'

(=(31) p.126, Miyagawa (1989))

The intransitive verbs in this class have transitive counterparts, yet the corresponding causative verbs with *sase* are not blocked. As Shibatani (1976) and Miyagawa note, the causative verbs of this type allow an analytical causative interpretation, as shown in the following examples:

- (12)a. Hanako-ga butai-ni agar-u
 Hanako-NOM stage-to rise-Present
 'Hanako rises onto the stage.'
- b. Taroo-ga Hanako-o butai ni ager-u
 Taroo-NOM Hanako-ACC stage to raise-Present
 'Taroo raises Hanako onto the stage.'

c. Taroo-ga Hanako-o butai-ni agar-ase-ru

Taroo-NOM Hanako-ACC stage to rise-Cause-Present

'Taroo causes Hanako to rise onto the stage.'

(=(19, 20 & 21) p.121, Miyagawa (1989))

aga 'rise' in (12a) is unergative, *age* 'raise' in (12b) is transitive and *agar-ase* in (12c) is the causative form derived from the intransitive stem plus the causative suffix. In the transitive construction in (12b), the subject of the verb performs the action of raising, directly causing the event to happen while in the causative construction in (12c) the object has risen onto the stage of its own accord, and the subject Taroo caused this to happen indirectly. Thus, if a transitive verb with a causative reading is listed in the lexicon, a causative form can be derived, but this derivation yields an analytical interpretation only.

Miyagawa also notes that an inanimate object such as a chair cannot be a causee in an analytical causative, as the contrast between (13) and (14) demonstrates.

(13) Taroo-ga isu -o butai ni ager-u

Taroo-NOM chair-ACC stage to raise-Present

'Taroo raises the chair onto the stage.'

(14)*Taroo-ga isu -o butai-ni agar-ase-ru

Taroo -NOM chair-ACC stage to rise-Cause-Present

'Taroo causes chair to rise onto the stage.'

(=(21) P.121, Miyagawa (1989))

He attributes the ungrammaticality of (14) to the unaccusativity of the verb 'agar'. The verb 'agar' selects a single argument; when the argument is animate, it is a subject at all levels of

representation, the verb an unergative verb. When the single argument is inanimate, it is underlyingly an object and the verb is unaccusative. In the analytical causative construction, the causer induces the causee to act, and consequently the analytical causation requires a causee with volitional control over its action. An inanimate causee, which cannot carry out an action of its own accord, would be incongruous with the analytical causative interpretation. Thus, unaccusative verbs, which select nonvolitional arguments, are not compatible with the analytical causatives.

5.2.2 Unblocked causatives

The unblocked causatives are derived from intransitive verbs which lack monomorphemic transitive counterparts. The following are examples of unblocked causative verbs (drawn again from Zenno 1985, cited in Miyagawa 1989):

(15) Intransitive Stem	Causative
sak 'bloom'	sak-ase 'bloom-cause' (=30g p.126, Miyagawa (1989))
kus 'rot'	kus-ase 'rot-cause'

Sak 'bloom' is an intransitive stem, and the corresponding causative verb is *sak-ase*, but there is no transitive counterpart. The unblocked class of causative verbs permits a lexical causative interpretation (16b).

- (16)a. Bara-ga sak -u.
 Rose-NOM bloom-Present
 'The rose blooms'

- b. Taroo-ga hana -o sak -ase -ru.
 Taroo-NOM flower-ACC bloom-Cause-Present
 'Taroo blooms the flower'

Miyagawa claims that only the unblocked causative verbs successfully enter the permanent lexicon. He demonstrates this by showing that permanent-lexicon processes such as an adversity interpretation and idiomatization apply to the unblocked causative, but not to the blocked causative verbs³. The following examples of adversity causative and idiomatic interpretation are from Miyagawa⁴:

- (17)a. Taroo-ga yasai -o kusar-ase -ta
 Taroo-NOM vegetable-ACC rot -Cause-Past
 'The vegetable rotted on Taroo.' (=38) p.129, Miyagawa (1989)
- b. Karera-ga hanashi -ni hana-o sak -ase -ru.
 they -NOM conversation-in flower-ACC bloom-Cause-Present
 'They are engaged in conversation heatedly'

Kusar-ase, which is an unblocked causative, may be associated optionally with the adversity causative interpretation, as shown in (17a), or idiomatization, as shown in (17b). When a verb is a blocked causative, the adversity interpretation and idiom formation are not

3

In the adversity interpretation, the causative morpheme *sase* has no causative meaning. The subject is not a causer of the event, but rather the one who is adversely affected by the core event.

4

Miyagawa (1989) also presents nominalization as a third piece of evidence that unblocked causatives are lexically listed.

available. Given that these types of semantic drift are observable in the unblocked causative as well as in some simple transitives, Miyagawa concludes that the unblocked causative can enter the permanent lexicon, whereas the blocked causative are syntactically derived and thus are not listed there.

Further to Miyagawa's analysis, we will subdivide the unblocked group into two subgroups, unaccusatives and unergatives, as the two classes yield different interpretations.

(18)	Intrans.Stem	Causative
a. unaccusative verb:	kus 'rot'	kus-ase 'rot-cause'
	sak 'bloom'	sak-ase 'bloom-cause'
b. unergative verb:	aruk 'aruk'	aruk-ase 'walk-cause'

(19)a.	Taroo-ga	yasai	-o	kusar-ase	-ta	
	Taroo-NOM	vegetable-ACC	rot	-Cause-Past		
	'The vegetable rotted on Taroo.'				(adversity)	
	'Taroo rotted the vegetable.'				(lexical)	

b.	Taroo-ga	hana	-o	sak	-ase	-ta.	
	Taroo-NOM	flower-ACC	bloom-Cause-Past				
	'The flowers bloomed on Taroo.'				(adversity)		
	'Taroo bloomed the flower.'				(lexical)		

(20)	Taroo-ga	Hanako-o	aruk-ase	-ta	
	Taroo-NOM	Hanako-ACC	walk-Cause-Past		
	*Hanako walked on Taroo.'				*(adversity)
	'Taroo caused Hanako to walk.'				(analytical)

The verbs 'rot' and 'bloom' in (19) are unaccusative. Their causative forms have the adversity or lexical causative interpretations. The causative form of the unergative verb 'walk' in (20) yields an analytical interpretation, but not an adversity or lexical interpretation.

5.2.3 Summary of blocked and unblocked causatives

The following chart summarizes the interpretations available for the causative forms of both blocked and unblocked verbs.

(21)	Stem	Lexical	Adversity	Analytical
Blocked				
Unergative	agar 'rise'	*ager	NO	agar-ase
Unaccusative	agar 'rise'	ager	NO	NO
Unblocked				
Unergative	aruk 'walk'	*aruk-ase	NO	aruk-ase
Unaccusative	kusar 'rot'	kusar-ase	YES	NO

The blocked unaccusative verbs have monomorphemic transitive forms, which yield a lexical causative interpretation. Affixing the causative morpheme *-sase-* to the unergative verb stems produces an analytical causative interpretation. Affixation of the causative morpheme to the unaccusative stem is ungrammatical. The causative form for unergative stems of the unblocked verbs has an analytical reading only. The unaccusative stems of this group may produce lexical or adversity interpretations after causativization.

The chart also indicates that the causative forms yield a lexical causative interpretation only when the root stem is unaccusative and has no monomorphemic transitive

counterpart in the lexicon. If the unaccusative stems do have a monomorphemic transitive form, the lexical causative is expressed by the monomorphemic transitive verb. An analytical causative is formed on a pre-existing lexical causative or monomorphemic transitive verb. It is never formed on unaccusative verb stems.

5.3 Structure of Japanese causatives

5.3.1 Pr and causative

In 2.6, we argued that Pr is a syntactic head responsible for projecting event structure onto syntax by introducing an object of initiation or actualization as a subject. Now, suppose another PrP is projected over this first PrP. It is reasonable to assume that an NP in Spec of the higher PrP initiates one sub-event, while an NP in the lower PrP initiates a second subevent. That is, an NP in Spec of the higher PrP may play the role of a causer of an event, while an NP in Spec of the lower PrP becomes a causee. This argument comes very close to the analysis developed by Ritter and Rosen (1993) for the English verb *have* and the Japanese causative *sase*. According to their analysis, *-sase*, like *have*, is a functor predicate which adds an external participant to an event. Thus, the analytical causative constructions are formed by adding an external participant to a core event. A similar argument is made by Harley (1995). Adopting Kratzer (1993), she proposes that EventP (Kratzer's VoiceP), which can optionally select an external argument, may take another EventP as its complement in the structure of the analytical causative. When EventP selects an external argument, its head is filled by an abstract element Cause, and the double EventP structure yields the analytical causative. Adopting their approaches, we propose that causativization is a process in which a second instigator is added to a core event. Since the object of initiation or actualization is

introduced by Pr, causativization results in a bipartite structure consisting of two PrPs; an NP in Spec of the higher PrP will be interpreted as a causer, and one in Spec of the lower PrP will be a causee. The verb undergoes head movement, raising through the lower Pr to the higher Pr. The relevant structure would be that shown in (22).

(22)a.

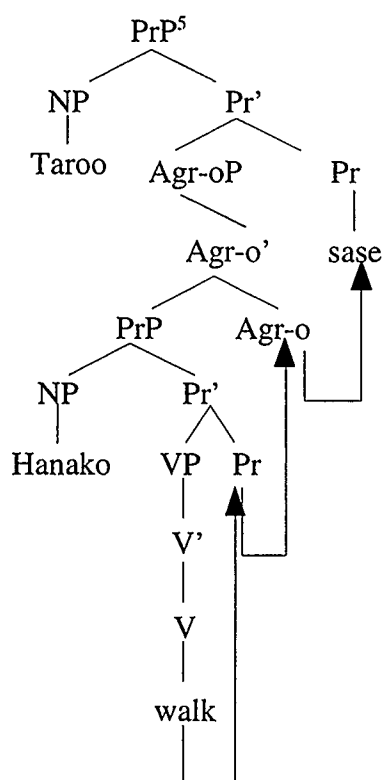

- b. Taroo-ga Hanako-o aruk-ase-ta
 Taroo-NOM Hanako-ACC walk-Cause-Past
 'Taroo caused Hanako to walk.'

However, the structure in (22) is not appropriate for a causativized unaccusative verb. As discussed in 2.6.4, we assume that an unaccusative verb has the following structure:

(23)a

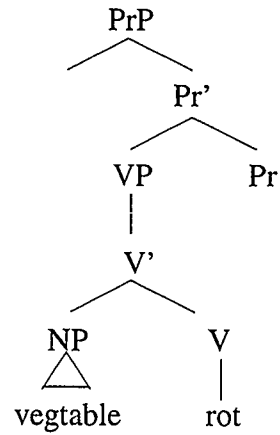

- b. Yasai -ga kusat-ta
 vegetable-NOM rot -Past
 'The vegetables rotted.'

Unaccusative verbs are eventive, thus requiring the Pr projection. An internal argument is generated in the complement position of V, and Spec of PrP is empty before the internal argument moves in. When unaccusative verbs undergo causativization, we propose that the following structure is produced:

(24)a.

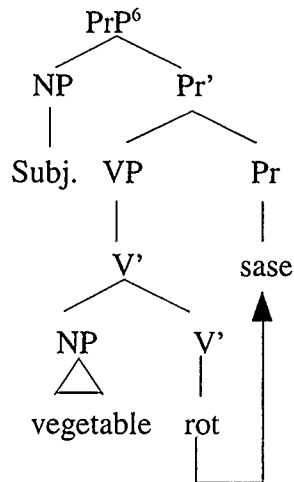

- b. Taroo-ga yasai -o kusar-ase -ta
 Taroo-NOM vegetable-ACC rot -Cause-Past
 'The vegetables rotted on Taroo.'

The bare unaccusative verb itself does not have an external argument, and it is reasonable to assume that the added external argument is inserted into the empty Spec of NP instead of projecting another PrP. Thus, causativization of unaccusatives results in a single PrP structure. We have assumed that Pr in unaccusatives is inert when Spec of PrP is empty. We speculate that once Spec of PrP is filled, the inert Pr becomes active. That is, unaccusatives, which do not have an external argument themselves, acquire an external argument and activate the exiting inert Pr through the causativization. Once Spec of PrP is filled with a causer and Pr is filled with the causative morpheme, V undergoes head movement to Pr covertly. The verb 'rot', which is an unblocked causative, does not have a lexical causative counterpart listed in the lexicon. Consequently the causative element is realized as the productive affix *-sase-*.

The upper PrP structure in (22) and the structure in (24) are very similar; both have the causative morpheme *-sase-* realized in Pr and a causer in Spec of the highest PrP. There is, however, a crucial difference in interpretation between the two verb + *sase* combinations. The structure in (22) yields an analytical causative interpretation, while that in (24) yields a lexical interpretation. In order to maintain a unified account of causatives which recognizes the semantic distinction between lexical and analytical causatives, yet permits realization of the same causative morpheme in both forms, we must assume that only the PrP which immediately dominates VP takes part in the word formation process. If it were completely independent of the lexicon or word formation domains, the causative form of unaccusative verb would not yield a lexical reading. This is contrary to fact. The causative form yields an adversity reading (24b), a lexical reading (25), or an idiomatic reading (26).

(25) Taroo-ga hana -o sak -ase -ru.

Taroo-NOM flower-ACC bloom-Cause-Present

'Taroo blooms flower.'

(26) Taroo-ga hana -o sak -ase -ru.

Taroo-NOM flower-ACC bloom-Cause-Present

· 'Taroo achieves a success.'

These non-analytical interpretations of the derived verb must be lexically listed. The adversity and idiomatic readings, which have undergone semantic drift, show that V + *sase* in (25-26) is a word, and not a syntactically formed verbal complex. Given the lexical properties of the causative V + *sase*, we must conclude that when there is only one PrP, this PrP participates in word formation; this PrP belongs to the lexicon, or to a domain which is not completely separate from the lexicon.

There is a clear distinction between the lower and upper PrP. The upper PrP is never involved in the word formation process. Moreover, the upper PrP never yields a lexical interpretation. This is shown in the causative form of unergatives. This distinction is also demonstrated by adding *sase* to a lexical causative. This results in the projection of an upper PrP, whose head is filled by *sase* and is assigned an analytical causative interpretation, as shown below.

(27)a.

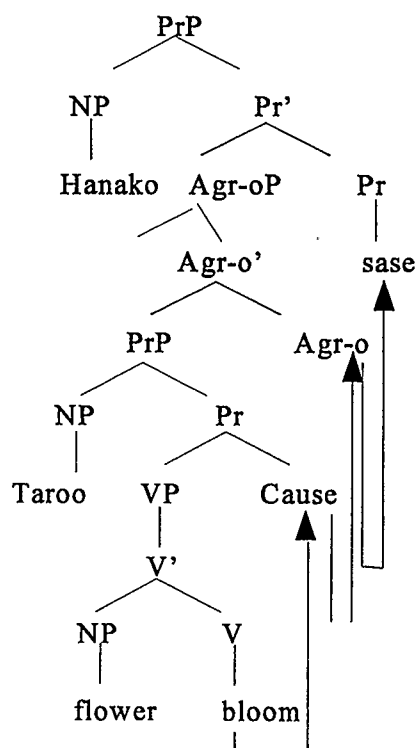

b. Hanako-ga Taroo-ni hana -o sak -ase -sase -ru.

Hanako-NOM Taroo-DAT flower-ACC bloom-Cause -Cause-Present

'Hanako makes Taroo bloom-cause flower.'

The upper causative never receives an idiomatic or adversity interpretation; it is always interpreted compositionally, as 'cause to V'. On our analysis, the V combines with the lower Pr in the lexicon and with the upper Pr in the syntactic component of the grammar. This distinction is consistent with the view of the lexicon and lexical derivation developed by Hale and Keyser (1994). They propose that lexical representations of predicates are hierarchically structured like syntactic representations of clauses, and that both types of representations are subject to the same kinds of structural constraints. On this view, the lexical representations of predicates constitute an l-syntax. Focusing on Japanese causatives, the structure consisting of the lower PrP and all it dominates would be projected from the lexicon, and would be accessible to lexical transformations. The upper PrP would only combine with this constituent in the syntactic component and, hence, would not be accessible to these lexical processes⁵.

In this subsection, we have argued that causativization is a process in which an additional PrP is added to a core event; an external argument in Spec of the added (upper)

5

Hale and Keyser (1994) assume the bipartite structure with a base VP and a VP-shell, where the base verb undergoes head movement to the VP-shell; and this VP-shell is projected into syntax. Our model, which assumes a lower PrP over a base VP, projects the lower PrP, not VP, into syntax, and this may be problematic. In the current literature, only lexical items are projected from the lexicon, not functional categories such as PrP. If we assume that VP-shell, not a lower PrP, is located over a base VP, we could avoid this problem; VP of a causative verb complex is projected into the syntax. However, we continue to use Pr for both upper and lower causative heads to capture the similarity of the lexical and analytical causative morphemes.

PrP is a causer and the argument in Spec of the lower PrP becomes a causee. Causativization of an unaccusative verb, which does not have an external argument, result in a single PrP structure, and yields a lexical interpretation. We have also argued that the causative form with a single PrP or lower PrP participates in word formation, producing a lexical causative interpretation. We will apply our framework to the other Japanese causatives in the next subsection, and show how the upper PrP and the core event structure contribute to the causative interpretation in each case.

5.3.2 The structure of unblocked causatives

Let us apply our framework to an unergative verb from the unblocked causative group. (28) shows the structure of a core event with an unergative VP. The single argument is an external one and is generated in Spec of PrP:

(28)

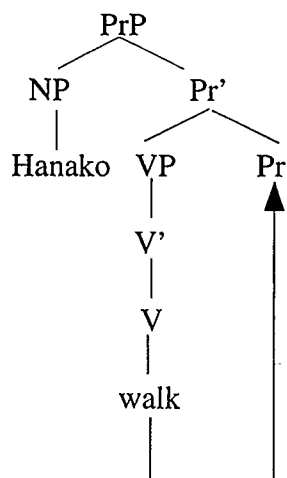

b. Hanako-ga arui-ta.

Hanako-NOM walk-Past

'Hanako walked.'

The addition of a second PrP triggers causativization of the event. The relevant structure would be that shown in (29) below:

(29)

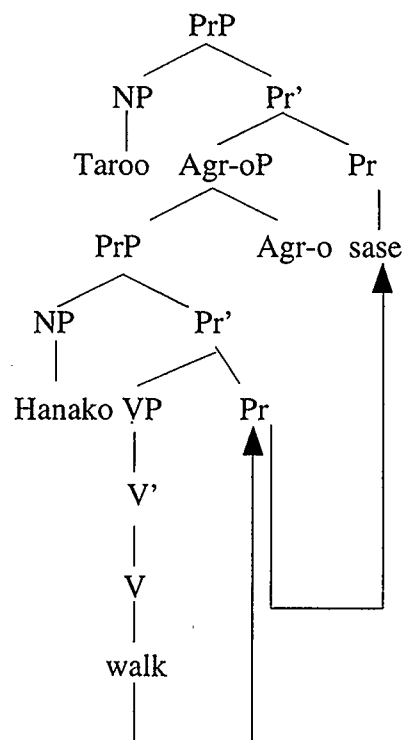

- b. Taro-ga Hanako-o aruk-ase -ta
 Taro-NOM Hanako-ACC walk-Cause-Past
 'Taro caused Hanako to walk.'

This structure has two initiators; one initiates the causing sub-event and the other initiates the caused or resultant sub-event. The lower PrP defines one sub-event, walking, which is initiated by Hanako. The upper PrP defines another sub-event, causing Hanako to walk, and this event is initiated by Taro. Thus, the interpretation obtained is analytical, as expected, given the double PrP structure. Since the upper PrP is not accessible to word formation processes, it cannot receive a lexical interpretation.

5.3.3 The structure of blocked causatives

Let us now examine the blocked causatives. When the verb *agar* 'rise' is used as an unergative, the structure contains a single PrP.

(30)a.

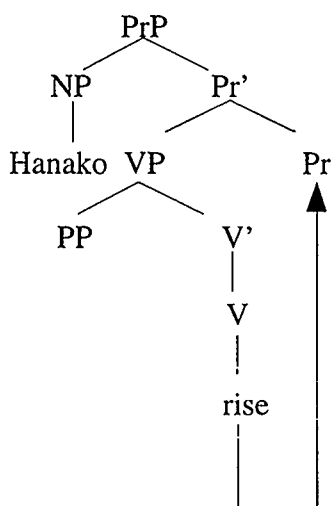

b. Hanako-ga butai-ni agaru.

Hanako-NOM stage-onto rise

'Hanako rises onto the stage.'

When this structure undergoes causativization, the structure shown in (31) results:

(31)a.

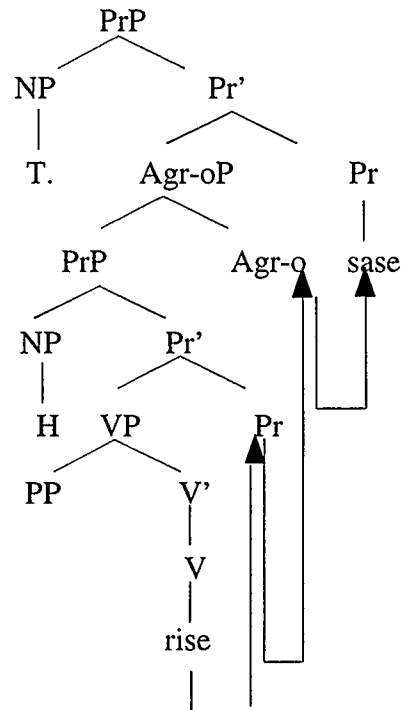

b. Taroo-ga Hanako-o butai-ni agar-ase-ta

Taroo-NOM Hanako-ACC stage-to rise-cause-past

'Taroo caused Hanako to rise onto the stage.'

When an unergative verb undergoes causativization, another PrP is projected. The argument

in Spec of the upper PrP is interpreted as a causer, and the argument in Spec of the lower PrP as a causee. Adding a causative PrP to this class of verbs always results in a double PrP structure, and as we have seen, a double PrP structure always yields an analytical interpretation.

Next, let us turn to the unaccusative verb stem, the structure of which is given in (32).

(32)

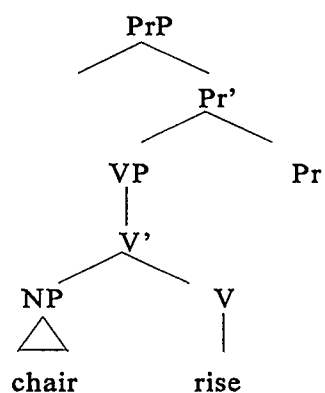

When (32) is causativized, a causer is inserted into the empty Spec of PrP. As a result, the causative structure looks like (33):

(33)a.

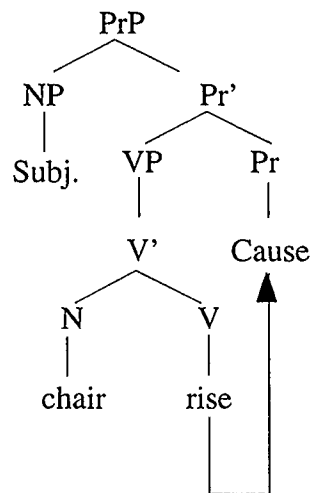

- b. Taroo-ga isu -o butai-ni age/*agar-ase -ta
 Taroo-NOM chair-ACC stage-to raise/rise-cause-past
 'Taroo raised a chair onto the stage.'
 *'Taroo caused the chair to rise onto the stage.'

The verb *agar* 'rise' has a transitive counterpart *ager* in the lexicon. When the verb *agar* raises to Pr, the abstract Cause element is realized as the lexical item *ager*, instead of the morphologically complex form *agar-ase*. This structure has a single PrP, thus it has a lexical interpretation. When the transitive form undergoes causativization again (i.e. when *sase* is added to *ager*), an upper Pr is projected, and an analytical causative results:

(34)a.

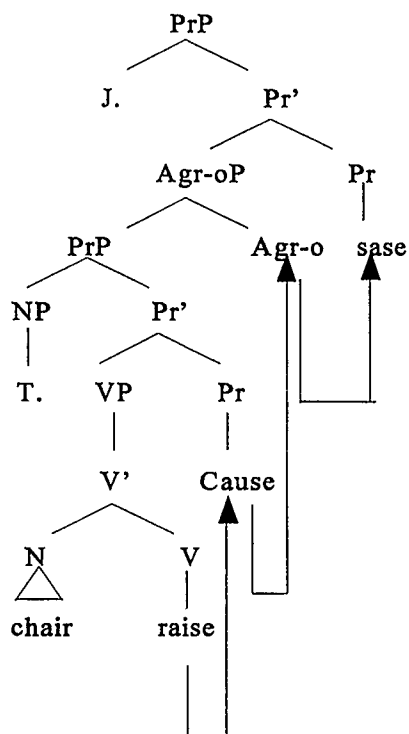

- b. Jim-ga Taroo-ni isu -o butai-ni age -ase -ta
 Jim-NOM Taro -DAT chair-ACC stage-to raise-cause-past
 'Jim made Taro raise the chair onto the stage.'

An animate causee such as 'Hanako' can be used with the analytical causative verb *agar-ase*, but an inanimate causee, such as 'chair' cannot, as illustrated in (35).

- (35) Taroo-ga Hanako/*isu -o butai-ni agar-ase -ta
 Taro-NOM Hanako/*chair-ACC stage-to rise-cause-past
 'Taro caused Hanako/the chair to rise onto the stage.'

This contrast is traditionally attributed to animacy, (Shibatani 1976), but it is easily accounted for syntactically in our framework: *agar-ase* 'rise-cause' is derived from an unergative stem, which requires an initiator subject in Spec of PrP: while *age-sase* 'raise-cause' is derived from an unaccusative stem, which does not have an initiator. Only an initiator subject which is generated in Spec of PrP can have the *agar-ase* form.

In this subsection we have demonstrated that causativization takes place when a second Pr projection is added to a core event. We also demonstrated the lower PrP is an interface between the lexicon and the syntax, thus a causative form with a single PrP yields an lexical causative interpretation. When unergatives undergo causativization, an additional Pr projection is required above the existing PrP, producing an analytical interpretation. When unaccusatives undergo causativization, the interpretation is lexical, as unaccusatives, which do not select an external argument themselves, simply activate the existing inert Pr projection through the causativization process.

5.3.4 The complement of the upper Pr

In 5.3.1 we stated that the upper PrP takes Agr-oP as its complement, without explaining why it must select the latter. In this section we present evidence to justify our assumption. We first look at data from the San Nicola dialect of Arbëresh, which has a causative structure similar to Japanese. Based on these findings, we suggest that Accusative and Dative Case in the Japanese causative are checked at Agr-oP and Agr-ioP, which are both generated under the upper PrP. We also demonstrate that the complement that the upper PrP selects does not contain a higher functional projection than Agr-oP, such as Negation or Tense.

5.3.4.1. The Case properties of causative structure

Linguists (Marantz 1984 and Baker 1988, among others) have shown that there are at least two types of morphologically complex causative constructions in languages. In the first type, the internal argument of the embedded clause is generally marked by Accusative Case while the embedded subject is marked by Dative. When passivization applies, the embedded object becomes the subject of the matrix clause. In the second type of causative, the embedded subject is generally marked by Accusative and the embedded object is marked by Accusative or Oblique Case. When passivization applies, the embedded subject becomes the matrix subject. Japanese belongs to the second type (Kuroda 1965 and others). Watanabe (1993) classifies the San Nicola dialect of Arbëresh into the second type and points out that the verb agreement in causatives is significant in analysing Case assignment in causative structure, citing examples from Guasti (1991 & 1992).

In the San Nicola dialect, the causative construction has a Dative subject when the base verb is transitive and an Accusative subject when it is intransitive.

(36)a. Maria bon të shurbenj Frankun.

Maria makes SP works Frank-ACC

'Maria makes Frankun work.'

b. Maria i bon të ghojirnj ghibrin ghnjarellit.

Maria him-DAT makes SP reads book-ACC child-DAT.

'Maria has the child read the books.'

(=(30 & 80) Turano 1989, cited as (27 & 28) p.146, Guasti (1992))

When the causative verb is passivized, the embedded subject becomes the matrix subject.

(37) Franku osht i bon të shurbenj

Franku was DET made SP works

'Franku was made to work.'

(=(29) Turano (1989), cited as (31) p.147 Guasti (1992))

The Case marking and passivization pattern are exactly the same in Japanese. The embedded subject is marked by Accusative Case when the verb is intransitive, and marked by Dative Case when it is transitive.

(38)a. Maria-ga Frank-o hatarak-ase -ru

Maria-NOM Frank-ACC work -Cause-Present

'Maria makes Frank work.'

b. Maria-ga kodomo-ni hon-o yom-ase -ru

Maria-NOM child-DAT book-o read-Cause-Present

'Maria makes the child read the book.'

When (38) is passivized, the embedded subject undergoes NP-movement as in the San Nicola dialect.

(39) Frank wa hatarak-ase -rare -ta

Frank-NOM work -Cause-Passive-Past

'Frank was made to work.'

According to Guasti (1991 & 1992), the verbs in this dialect are inflected for tense and

agreement, differing from Japanese; and the lower verb always agrees with the lower subject, whether it is marked by Dative or Accusative⁶. What is crucial is that the lower subject does not agree with the matrix verb. This suggests that the embedded subject checks its Case at Agr-oP or Agr-ioP, both of which are generated just above the base verb, not above the matrix causative verb.

Japanese verbs and nouns do not exhibit agreement, but given the similarity of the causative structure between Japanese and the Arbëresh dialect, it is reasonable to generalize the findings from this dialect to Japanese in order to analyze the Japanese Case properties. We propose the following structure for the Japanese causatives when the core verb is intransitive:

⁶

As Watanabe (1993) points out, Guasti (1991 & 1992) does not provide examples which clearly show that the embedded subject agrees with the base verb and not the matrix causative verb.

(40)

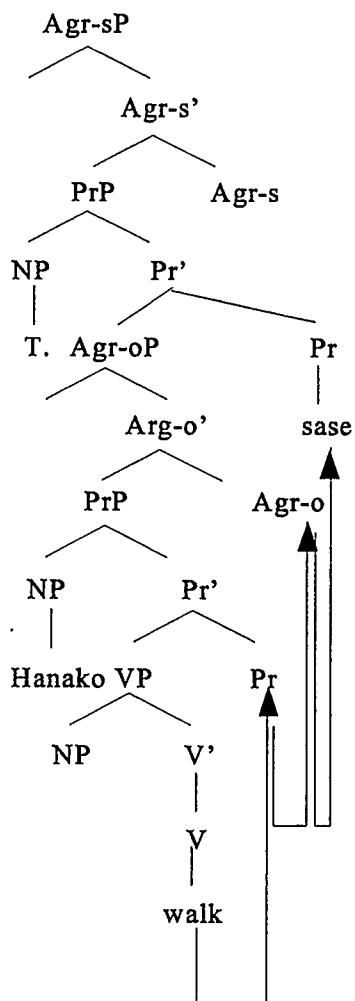

- b. Taroo-ga Hanako-o aruk -ase -ta
 Taroo-NOM Hanako-ACC walk-Cause-Past
 'Taroo caused Hanako to walk

When the core verb is intransitive, the subject of the core verb checks its Case at Agr-oP and

bears Accusative Case. The NP on Spec of PrP checks its Case at Agr-sP above the upper PrP and bears Nominative Case.

When the verb is transitive, we suggest that Agr-ioP is projected above Agr-oP as shown below:

(41)a.

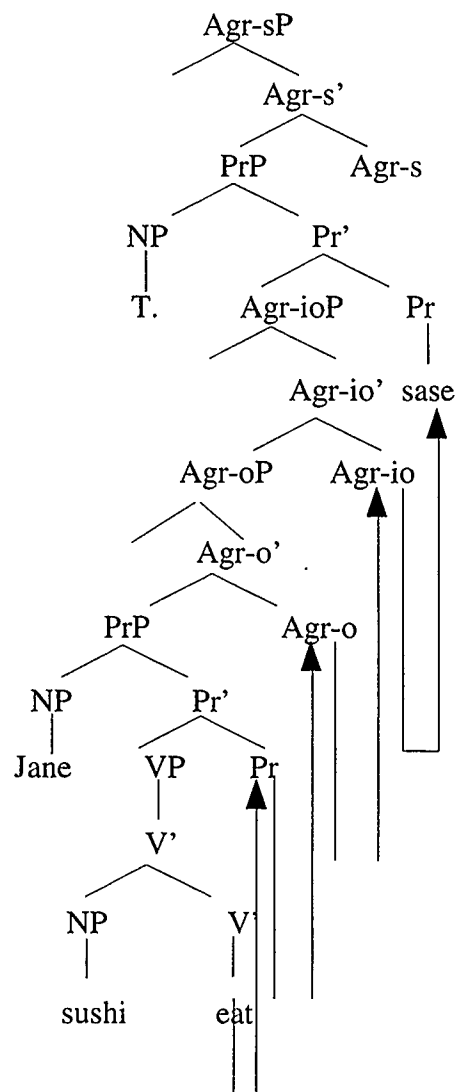

b. Tom-ga Jane-ni sushi-o tabe-sase -ta.

Tom-NOM Jane-DAT sushi-ACC eat -Cause-Past

'Tom caused Jane to eat sushi.'

The subject of the core verb 'Jane' bears Dative Case, and its object 'sushi' bears Accusative Case. Given the Arbëresh facts which show that the Dative Case-marked embedded subject always agrees with the lower verb, we will now assume that Agr-ioP, which is responsible for Dative Case checking, is projected above Agr-oP but under the upper PrP. Thus, the subject of the core verb bears Dative Case, checking its Case at Agr-ioP; and the object of the base verb bears Accusative Case, checking the Case at Agr-oP in transitive verbs.

The structure in (40) and (41) is radically different from the one generally proposed by the linguists who argue for syntactic formation of Japanese analytical causatives. Accusative Case assignment to the embedded object poses no problem. The object receives Accusative Case from the base verb. However, they invariably assume that the embedded subject receives Accusative Case from 'cause', not the base verb, although the details vary (Kuroda 1965, Kuno 1973, Shibatani 1990). They further argue that the Dative Case marking of the embedded subject in the case of transitive verbs is due to the language-specific surface constraint called the Double-O constraint, which disallows the occurrence of two accusatively marked objects in a clause. When there are two NPs which bear Accusative Case, one Case marking is realized as *ni* and the other as *o*. With our approach, all Accusative Case and Dative Case marked NPs are checked at functional projection under the upper Pr, one Agr-oP and one Agr-ioP. Spec of Agr-oP is accessible to the object of the core event if there is one and the causee otherwise. The availability of only one Agr-o seems to be a more straightforward explanation than the "Double-o constraint".

5.3.4.2 Neg and Tense Projections

We have argued that the upper PrP selects Agr-oP as its complement. In this subsection we demonstrate that the upper PrP does not select a higher projection than Agr-oP, -such as NegP or TP, -as its complement. If it did, the constituent that denotes the caused event could have negation and tense elements.

Ritter and Rosen (1993) demonstrate that the English causative and experiencer *have* selects a bare VP complement; its complement contains no inflectional material such as tense and negation⁷. (42) is their evidence to support the claim that there is no NegP in the complement of *have*.

(42)a. Pat didn't make Terry cheat on the test, but she did it anyway.

b. *Pat didn't have Terry cheat on the test, but she did it anyway.

The ungrammaticality of the 'but' clause in (42b) shows that the core event *cheat* as well as the causing event *have* has been negated by *didn't*. This is because one NegP has scope over both the causing event and the core event, and the 'but' clause contradicts the claim made in the first part of the sentence. Guasti (1992) argues similarly for a bare VP complement in the Romance causative *faire-infinitive* construction. (43) is evidence used to show that the complement has no tense projection.

(43)*Ieri Marco ha fatto pulire le toilette al generale oggi
 yesterday Marco has made clean the toilets to the general today

7

Ritter and Rosen leave open the possibility that the complement of *have* may be some functional projection below TP and NegP such as Agr-oP.

'Yesterday, Marco had the general clean the toilets today.'

Assuming that temporal adverbials are licensed by the tense projection (Marantz 1984), she argues that the ungrammaticality of this example shows that there is only one TP within causative sentences, which licenses one adverb, leaving the other unlicensed.

Similar arguments can be made in order to demonstrate that the complement of *sase* does not contain NegP and TP. (44) shows the construction with negation in the complement.

- (44) *Taroo-ga Hanako-o aruk -na -sase -ta
 Taroo-NOM Hanako-ACC walk-Neg-Cause-Past
 'Taroo caused Hanako not to walk.'

The ungrammaticality shows that negation cannot be in the complement; *sase* does not select Neg projection as its complement.

(45) shows that the causative structure cannot have two temporal adverbs.

- (45) *Kinou Taroo-ga Hanako-o kyou aruk-ase -ta
 Yesterday Taroo-NOM Hanako-ACC today walk-Cause-Past
 'Yesterday Taroo had Hanako walk today.'

If we assume that temporal adverbs are associated with a tense projection, following Guasti, the ungrammaticality of (45) can be accounted for in the same way as for the *fair-infinitive* causative. *Kinou* 'yesterday' and *kyou* 'today' need two TPs in order to be licensed. When one adverb is deleted, as shown below, the sentence becomes grammatical, and the interpretation is that the cause and the core event occur at the same time, depending on which adverb is used.

- (46)a. Kinou Taroo-ga Hanako-o aruk -ase -ta
 Yesterday Taroo-NOM Hanako-ACC walk-Cause-Past
 'Yesterday Taroo had Hanako walk.'
- b. Taroo-ga Hanako-o kyou aruk-ase -ta
 Taroo-NOM Hanako-ACC today walk-Cause-Past
 'Taroo had Hanako walk today.'

The contrast between (45) and (46) suggests that the core event does not have its own TP, but that it shares a single TP with *sase*. This TP has scope over the cause and the result. Example (47) below provides further support.

- (47) Kinou Taroo-ga Hanako-o kyou aruku-yoo itta
 Yesterday Taroo-NOM Hanako-ACC today walk-Nominalizer told
 'Yesterday Taroo told Hanako to walk today.'

(47) is grammatical with two adverbs, suggesting that the verbs 'told' and 'walk' project TP separately, and the TP associated with each of the verbs hosts one adverb. The contrast between (45) and (47) clearly indicates that the causative structure does not have the same functional projections as the expression in (47) does.

Shibatani (1976) notes that modification by a time phrase may be ambiguous in interpretation.

- (48) Taroo-ga Ziroo-o rokuji-ni oki -sase -ta
 Taroo-NOM Ziroo-ACC six-at get up-Cause-Past
 'Taroo made Ziroo to get up at six o'clock.' (= (9), p.244 Shibatani (1976))

(48) has two possible interpretations, namely:

(49) (i) Ziroom's getting up took place at six o'clock (with the understanding that the cause event occurred before six o'clock).

(ii) The cause event and the core event both took place at six o'clock.

The first interpretation, that the cause event took place before the core event, seems to contradict our claim that the causative has a single TP which has scope over both the cause and the core event. This interpretation, however, does not necessarily constitute counterevidence to our claim. It seems that this interpretation arises because of semantic properties of the *sase* morpheme, not because of two TPs. The cause morpheme seems to display the semantics of accomplishment verbs. Accomplishment may take a certain amount of time to fulfil (Vendler 1967).

(50) John ate the pie in an hour.

(=(32) p.72, van Voorst (1988))

The adverb denotes the final point of this event 'eating the pie'. The cause morpheme *sase* has similar semantic properties; a certain time may pass before realization of the core event after the initiation of the cause event. In (48), the core event, Ziroom's getting up, denotes the end point of the cause event, and it might not occur at the same time Ziroom initiated the cause event. A certain amount of time may elapse between the cause event and the core event. Thus, (48) has two ambiguous interpretations depending on how long it took for the cause event to accomplish its task. If the cause event accomplishes the core event instantly, interpretation (49ii) is produced; otherwise interpretation (49i) results. Thus, the ambiguous interpretation arises due to the semantic properties of the cause morpheme, not due to two tense projections.

The evidence from temporal scope and negation as well as Accusative Case support the proposed structure, where *sase* selects Agr-oP, not a higher or lower projection.

5.4 Reflexive Binding

As noted in section 5.1.1, Kuno (1973), Shibatani(1976) and others have argued that the Japanese analytical causatives have a biclausal structure on the basis of reflexive binding facts. In the last section, we argued that all Japanese causatives have a monoclausal structure. In this section we provide an account of the reflexive binding facts consistent with our analysis.

In section 5.1.1, we saw that the Japanese analytical causatives behave ambiguously towards reflexive binding; the reflexive pronoun may refer to the causer or the causee, as shown in (51).

- (51) Taroo-ga_i Hanako-o_j jibun-no_{i/j} heya-de aruk -ase -ta
 Taroo-NOM Hanako-ACC self -GEN room-in walk-Cause-Past
 'Taroo_i caused Hanako_j to walk in self_{i/j}'s room.'

This example contrasts with the lexical causatives, which allow only the causer to bind a reflexive phrase.

- (52) Taroo-ga_i Hanako-o_j jibun-no_{i/*j} heya-de kusugutta.
 Taro-NOM Hanako-ACC self-GEN room-in tickled
 'Taroo_i tickled Hanako_j in self_{i/*j}'s room.'

These data seem to provide strong motivation for positing a biclausal structure of the

analytical causatives, contradicting the morphological evidence for simplex underlying structure discussed in the previous section. The reflexive binding data, however, pose no problem for our analysis. Grimshaw (1990) proposes that in Japanese the antecedent of a reflexive phrase is the bearer of the highest thematic role, and not necessarily the subject of a sentence (see also Uda (1991)). Accordingly, an analytical causative in Japanese consists of two morphemes, each of which has its own argument structure. The causative affix has an argument structure wherein the causer NP is thematically most prominent; and the core verb also has its own argument structure. When causativization occurs, each of the two morphemes brings its own argument structure, and the most prominent arguments of each structure both remain most prominent in the causative phrase. As a result, the causer and the causee, thematically maximally prominent arguments, act as the antecedent of an anaphor in the causative.

Grimshaw makes the standard assumption that each verb has a theta grid (and the non-standard assumption that each verb also has an aspectual grid). In other words, each argument selected by a given verb receives a theta role and an aspectual role. She further assumes that analytical causative constructions require a causative verb and a main verb and that each verb assigns its own theta and aspectual roles. The causer receives the theta role of agent from the causative verb and the causee receives the theta role of agent from the main verb. Since analytical causative constructions have two most prominent arguments, the agent of the causative verb and the agent of the main verb, they allow two reflexive binding options.

In chapter 2, we proposed that Pr, a functional, or perhaps more accurately, a quasi-lexical category, assigns the event role of initiator to the external argument in Spec of PrP. Suppose that Pr-V complex also assigns the theta role of agent to this argument. This captures the insight that external arguments are somehow unique. Suppose that in fact the binder of *jibun* is the external argument which receives its theta role from Pr. Now in an

analytical causative clause, which contains two Pr elements, there will be two possible binders for *jibun*, as on Grimshaw's analysis.

An example of the analytical causative is repeated below.

- (53)a. Taroo-ga Hanako-o jibun-no heya-de aruk -ase -ta
 Taroo-NOM Hanako-ACC self -GEN room-in walk-Cause-Past
 'Taroo_i caused Hanako_j in self_{i/j}'s room to walk.'
- b. Taroo-ga Hanako-o jibun-no butai-ni agar-ase -ta
 Taroo-NOM Hanako-ACC self's stage-to rise-cause-past
 'Taroo_i caused Hanako_j to rise onto self_{i/j}'s stage.'

(53a) is the unblocked causative and (53b) is the blocked causative. The stem verbs are both unergative, and the causative forms take on the analytical interpretation only. Each sentence has two initiator NPs, which are the most prominent arguments in terms of thematic role. The ambiguous readings show that the reflexive takes both initiators as its antecedent, as Grimshaw's theory predicts.

The next example contains the unaccusative verb 'die'.

- (54) Taroo-ga Hanako-o jibun-no ie -de shin-ase -ta
 Taroo-NOM Hanako-ACC self's house-in die -cause-past
 'Taroo_i had Hanako_j die on him in self_{i/*j}'s house.'
 *'Taroo made Hanako die in self's house.'

The causative form of the unaccusative verb 'die' yields an adversity interpretation, but not an analytical interpretation. (54) has only one initiator, the causer, as the unaccusative verb

does not have an initiator subject. Thus, the reflexive takes only the causer as its antecedent, as predicted.

5.5. Summary

In this chapter, we have proposed that a verb undergoes causativization when PrP is added to an event. Following Miyagawa (1994), we assumed that Pr will be realized either as the causative morpheme *sase*, or as part of a lexical transitive verb. We have demonstrated that lexical versus analytical interpretations are due to the interplay between Pr and the core event structure. An unaccusative verb, which only assigns an internal argument, will yield a lexical causative interpretation when causativized. An unergative verb, which has its own PrP projection, will form a double PrP structure in a causative construction, and thus produce only an analytical causative. We have also accounted for the apparent biclausal properties of the causative with respect to reflexive binding.

Chapter 6

CONCLUDING REMARKS AND FURTHER ISSUES

6.1 Concluding remarks

This thesis has presented an analysis of subject position in nonstative and stative structures and posited a functional projection Pr below Agr-oP but above VP. Firstly, we have proposed PrP based on structural considerations. We have reviewed the [Spec, IP] Subject Hypothesis and the [Spec, VP] Subject Hypothesis, and noted evidence counter to these hypotheses. To accommodate this counterevidence, we have proposed a functional projection, which introduces a subject.

Secondly, we have examined the semantic properties of Pr, and suggested that Pr plays a role in projecting an event structure onto the syntax. Following van Voorst, we have identified the subject of nonstative verbs in Japanese the initiator of an event, which consists of a beginning and an end. The beginning of the event is denoted by the subject, which is an initiator in Japanese, and the end is denoted by the object. This framework led to a hypothesis that the unaccusative construction also has PrP because unaccusative verbs are eventive. Based on the properties of unaccusatives discussed in the literature, we speculated that Pr in unaccusative structure is inert when it does not introduce the object of origin in Spec of PrP. We also suggested that stative verbs, which do not denote an event, have no PrP, and consequently the subject is base-generated in Spec of VP.

Thirdly, we have provided independent evidence to support the structure of statives and nonstatives from VP-preposing. Assuming that VP-preposing is fronting VP, the fact that nonstative verbs generally undergo VP-preposing suggests that the subject of nonstative verbs is outside VP. Stative verbs, which do not undergo preposing, then must project the subject inside VP.

addition of an instigator to a core event, generally resulting in a bipartite structure consisting of two PrPs. The analyses of causatives as well as statives provided further support to our claim that PrP is a functional projection whose semantic contribution consists of aspectual information pertaining to the subject argument.

Finally, given the revised version of the Case-assignment mechanism, we have proposed that Pr is an Accusative Case-bearing head, not V as generally assumed in the Minimalist Program. Accusative Case is checked in Spec of Agr-oP against an NP when the V + Pr complex adjoins to Agr-o. Moving on to speculate about the Nominative object in the stative structure, we have suggested that Nominative Case marking of the object in statives is due to lack of PrP; the object of such verbs cannot check its Case in Spec of Agr-oP because the Case-bearing head Pr is not projected, and it realizes its Case as Nominative Case. While it is admittedly speculative, we hope that this may help to account for the lack of Accusative Case in the unaccusative structure.

6.2 Further Issues

Finally, we would like to touch upon two issues which we have not discussed in the paper, namely passives and adjectives. Passivization is generally analyzed as involving the absorption of the external theta role and Accusative Case. These properties strongly suggest involvement of PrP in the passivization process. As we have discussed throughout the paper, the main functions of PrP are to introduce a subject and to check the Accusative Case features of the object. Suppose passivization is a process which suppresses PrP, so that PrP will lose its ability to introduce the subject and check the Accusative Case features in the passive structure. As a consequence, the subject will be demoted to an adjunct position, and the object will raise to Spec of Agr-sP to check Case, appearing as a subject.

If passivization is analyzed as suppression of PrP, it follows that only structures with

PrP will undergo this process. This simple prediction seems to explain some of peculiarities of passivization in Japanese. First, stative verbs do not undergo passivization, since they lack PrP.

(1)a. Tom-ni yama -ga mieru.

Tom-to mountains-Nom can see.

'Tom can see mountains.'

b.*Yama -ga Tom-niyotte mier -are -ru

mountains-NOM Tom-by can see -Passive-Present

'Mountains can be seen by Tom.'

Secondly, unaccusative verbs which have PrP will undergo passivization. In English they do not passivize, but in Japanese they do, yielding an adversity passive interpretation, as shown below.

(2)a. Tsuma-ga shin-da.

Wife-Nom die -Past

'The wife died.'

b. Tom-ga tsuma-ni shin-are -ta

Tom-Nom wife -by die -Passive-Past

'Tom was adversely affected by the event that his wife died.'

Passivization in Japanese is rather complicated, involving two kinds of passive structure, direct passive and adversity passive, and a thorough investigation of passives is required to examine the possible involvement of PrP. Given the properties of passives, however, the present framework seems be able to offer a straightforward analysis for passives by arguing

that passivization in Japanese is an event structure operation, suppressing PrP. We leave this issue for future research.

This analysis also has implications for the analysis of adjectives. In Japanese, the set of lexical items that correspond to adjectives in other languages can be divided into two classes. Members of the first class behave like verbs. They can function as predicates without the support of a copula and they inflect for tense. The second class of so-called adjectives have the properties of nouns. They do not inflect for tense and they share other properties with nouns. Most of the adjectives in both classes select a single, Nominative Case-marked argument, as illustrated in (3) and (4).

(3)a. Hon -ga akai

book-NOM red

'The book is red.'

b. Hon -ga akakat-ta

book-NOM red -Past

'The book was red'

(4) Kore-ga kirei -da

this-NOM pretty-COP

'This is pretty.'

These facts would follow from our analysis assuming that both are stative predicates, the class of verb-like adjectives are stative verbs, and the class of noun-like adjectives are adjectives (or nouns) supported by a null copula. However, transitive adjectives of both classes pose a problem for the analysis of stative verbs developed in chapter 4. As illustrated in (5) and (6) below, the subject of a transitive adjective of either class is Case-marked by

the topic marker *-wa* rather than the dative postposition *-ni*.

(5)a. Tom-wa piza -ga hoshii.

Tom-TOP pizza-NOM want

'Tom wants pizza.'

b.*Tom-ni piza -ga hoshii.

Tom-NOM pizza-NOM want

'Tom wants pizza.'

(6)a. Tom-wa piza -ga suki-da.

Tom-TOP pizza-NOM like-COP

'Tom likes pizza.'

b.*Tom-ni piza -ga suki-da.

Tom-to pizza-NOM like-COP

'Tom likes pizza.'

As was the case with the stative verbs discussed in chapter 4, when the subject of a stative adjective bears the Nominative Case marker *-ga*, an exhaustive list reading obtains.

(7)a. Tom-ga piza -ga hoshii.

Tom-NOM pizza-NOM want

'It is Tom who wants pizza.'

b. Tom-ga piza -ga suki-da.

Tom-NOM pizza-NOM like-COP

'It is Tom who likes pizza.'

The object of stative adjectival predicate never receives Accusative Case. This is consistent

with our proposal that PrP is not present in a stative clause. However, the problem of Case-marking the subject of adjectival and of accounting for the cluster of verbal and nominal properties associated with the two subclasses of adjectives must be addressed in future research on this topic.

BIBLIOGRAPHY

- Baker, M. (1988) *Incorporation: A theory of Grammatical Function Changing*, University of Chicago Press, Chicago.
- Borer, H. (1993) "The Projection of Arguments," in E. Benedicto, and J. Runner, ed., *University of Massachusetts Occasional papers in Linguistics*, Vol 17.
- Bowers, John. (1993) "The Syntax of Predication," *Linguistic Inquiry* 24.4, pp.591-656.
- Chomsky, Noam. (1986) *Barriers*, MIT Press, Cambridge, Massachusetts.
- Chomsky, Noam. (1991) "Some Notes on Economy of Derivation and Representation," in R. Freidin, ed., *Principled and Parameters in Comparative Grammar*, MIT Press, Cambridge, Massachusetts.
- Chomsky, Noam. (1992) "A Minimalist Program for Linguistic Theory," *MIT Occasional Papers in Linguistics*, Number 1, 1992.
- Farmer, A.K. (1984) *Modularity in Syntax: A Study of Japanese and English*, MIT Press, Cambridge, Massachusetts.
- Fukui, N., and P. Speas (1986) "Specifiers and Projection," in N. Fukui, T. Rapport, and E. Sagey, eds., *MIT Working Papers in Linguistics* Vol. 8, 128-172.
- Grimshaw, Jane and Strang Burton (1992) "Coordination and VP-Internal Subjects," *Linguistics Inquiry* 23, pp.305-313.
- Guasti, Maria Teresa (1992) *Causative and Perception Verbs*, Doctorial Dissertation, Universite de Geneve
- Guilfoyle, E. (1995) "VNPs, Finiteness and External Arguments" Unpublished ms, University of Calgary
- Hale, K. and J. Keyser (1994) "On argument structure and the lexical expression of syntactic relations," in Hale and Keyser eds., *The View from Building 20*, pp.53-109, MIT Press, Cambridge, Massachusetts.

- Halle, M. and A. Marantz (1994) "Distributed Morphology," in Hale and Keyser eds., *The View from Building 20*, pp.53-109, MIT Press, Cambridge, Massachusetts.
- Harada, S.I. "Honorifics," in M. Shibatani, ed. *Syntax and Semantics 5: Japanese Generative Grammar*, Academic Press, pp.499-561.
- Harley, H. (1995) *Subjects, Events and Licensing*, Doctorial Dissertation, MIT
- Hoji, H., S. Miyagawa and H. Tada (1989) "NP-Movement in Japanese," ms., University of Southern California, Los Angeles, Ohio State University, Columbus, and MIT, Cambridge.
- Huang, C.-T. James (1993) "Reconstruction and the Structure of VP: Some Theoretical Consequences," *Linguistic Inquiry* 24, pp.103-138.
- Jonas, D., and J. D. Bobaljik (1993) "Specs for Subjects: the Role of TP in Icelandic," in J.D. Bobaljik and C. Phillips, eds., *Papers on Case and Agreement I*, MITWPL Vol.18, pp. 59-98.
- Johnson, Kyle (1991) "Object Positions," *Natural Language and Linguistic Theory* 9.4, pp.577-636.
- Kayne, R.S. (1989) "Facets of Romance Past Participle Agreement," in P. Benincà, ed., *Dialect Variation and the Theory of Grammar*, Foris, pp.85-103.
- Kitagawa, Y. (1986) *Subjects in Japanese and English*, Doctoral dissertation, University of Massachusetts, Amherst, Massachusetts.
- Koizumi, M. (1993) "Object Agreement and the Split VP Hypothesis," in Jonathan D. Bobaljik and Colin Phillips, eds., *Papers on Case and Agreement I*, MITWPL Vol.18, pp.99-148.
- Koopman, H. and D. Sportiche, (1991) "The Position of Subjects," *Lingua* 85, pp.211-258
- Kratzer, A. (1993) "The Event Argument and the Semantics of Voice" Unpublished ms. University of Massachusetts, Amherst, Massachusetts.
- Kubo, M. (1992) *Japanese Syntactic Structures and their Constructional Meanings*, Doctoral dissertation, MIT, Cambridge, Massachusetts.
- Kuno, S. (1973) *The Structure of the Japanese Language*, MIT Press, Cambridge, Massachusetts.

- Kuno, S. (1978) "Japanese: A Characteristic OV Language," in W.P. Lehmann ed., *Syntactic Typology: Studies in the Phenomenology of Language*, pp.57-138, University of Texas Press, Austin.
- Kuroda, S.-Y. (1988) "Whether We Agree or Not," *Linguisticae Investigations* 12, pp.1-47.
- Lasnik, H. and M. Saito (1992) *Move α* , MIT Press, Cambridge, Massachusetts.
- Mahajan, A.K. (1990) *The A/A-bar Distinction and Movement Theory* Doctoral dissertation, MIT, Cambridge, Massachusetts.
- Marantz, A. (1984) *On the Nature of Grammatical Relations*, MIT Press, Cambridge, Massachusetts.
- McNally, Louise (1992) "VP Coordinations and the VP-Internal Subject Hypothesis," *Linguistic Inquiry* 23, pp.336-341.
- Miyagawa, S. (1989) *Syntax and Semantics 22: Structure and Case Marking in Japanese*, Academic Press, New York.
- Miyagawa, S. (1994) "Sase as an Elsewhere Causative," in the program of *Linguistic Theory and Japanese Language Teaching*, Seventh Symposium on Japanese Language, Tsuda Japanese Language Centre
- Nakayama, Mineharu and Masatoshi Koizumi (1991) "Remarks on Japanese Subjects," *Lingua* 85, pp.303-319.
- Nemoto, N. (1993) *Chains and Case Positions: A Study from Scrambling in Japanese*, Doctoral dissertation, MIT, Cambridge, Massachusetts.
- Pesetsky, D. (1989) "Language Particular Process and the Earliness Principle," ms, MIT.
- Pesetsky, D. (1994) *Zero Syntax*, MIT Press, Cambridge.
- Pollock, J.-Y. (1989) "Verb Movement, Universal Grammar, and the Structure of IP," *Linguistic Inquiry* 20, pp.365-424.
- Ritter, E. and S.T. Rosen (1993) "Deriving Causation," *Natural Language and Linguistic Theory* 11, pp.519-555.
- Rizzi, L. (1990) *Relativized Minimality*, MIT Press, Cambridge.
- Roberts, I. (1990) "Some notes on VP-fronting and head government" in J. Mascaro and M.

- Nespor, eds., *Grammar in progress*, pp.387-396, Foris, Dordrecht.
- Ross, J. R. (1967) *Constraints on Variables in Syntax*, Doctoral dissertation, MIT, Cambridge, Massachusetts.
- Sadakane, K. and M. Koizumi (1995) "On the Nature of the 'Dative' Particle *ni* in Japanese," *Linguistics* 33, pp.5-33
- Saito, M. (1985) *Some Asymmetries in Japanese and Their Theoretical Implications*, Doctoral dissertation, MIT.
- Shibatani, M. (1973) "Semantics of Japanese causativization," *Foundations of Language* 9, 327-373
- Shibatani, M. (1976) "Causativization," in M. Shibatani, ed. *Syntax and Semantics 5: Japanese Generative Grammar*, Academic Press, pp.239-294.
- Shibatani, M. (1990) *The Languages of Japan*, Cambridge University Press, Cambridge.
- Sportiche, D. (1988) "A Theory of Floating Quantifiers and its Corollaries for Constituent Structure," *Linguistic Inquiry* 19, pp.425-449.
- Stowell, T. (1981) *Elements of Phrase*, Doctoral dissertation, MIT, Cambridge, Massachusetts.
- Takano, Yuji (1995) "Predicate Fronting and Internal Subjects," *Linguistic Inquiry* 26, pp.327-340.
- Takezawa, K. (1987) *Configurational Approach to Case Marking in Japanese*, PhD dissertation, University of Washington
- Tateishi, K. (1991) *The Syntax of "Subjects"*, Doctoral dissertation, University of Massachusetts, Amherst.
- Terada, M. (1990) *Incorporation and Argument Structure in Japanese*, PhD dissertation, University of Massachusetts, Amherst.
- Travis, L. (1994) "Event phrase and a theory of functional categories," paper presented at the Canadian Linguistics Association meeting, 1994, University of Calgary.
- Uda, C. (1994) *Complex Predicates in Japanese. Outstanding Dissertations in Linguistic series*, Garland Press,

- Ueda, M. (1990) *Japanese Phrase Structure and Parameter Setting*, Doctoral dissertation, University of Massachusetts, Amherst.
- Van Voorst, J. (1988) *Event Structure. Current Issues in Linguistic Theory* 59, John Benjamins, Amsterdam.
- Watanabe, Akira (1993) *Arg-Based Case Theory and Interaction with the A-bar System*, MIT dissertation, Cambridge, Massachusetts.
- Whiteman, J. (1986) "Configurationality Parameters, in T. Imai and M. Saito, eds., *Issues in Japanese Linguistics*, pp. 351-374, Foris, Dordrecht.
- Williams, E. S. (1980) " Predication," *Linguistic Inquiry* 11.1, pp.203-239.
- Zenno, Y. (1985) *Paradigmatic Structure and Japanese Idioms*, Masters thesis, Ohio State University, Columbus.